

BENNA A POLIPO PER MOVIMENTAZIONE ROTTAME E MATERIALI VARI  
POLYP-GRAB FOR SCRAP'S AND DIFFERENT MATERIALS' HANDLING  
GRAPPIN POUR LA MANIPULATION DE LA FERRAILLE ET DE MATÉRIAUX DIVERS  
MEHRSCHALENGREIFER FÜR SCHROTT-UND VERSCHIEDENEN MATERIALUMSCHLAG  
PULPOS PARA CHATARRA Y MATERIALES DIVERSOS  
ПОЛИП – ГРЕЙФЕР ДЛЯ ПОГРУЗКИ МЕТАЛЛОЛОМА И РАЗЛИЧНЫХ МАТЕРИАЛОВ

1

DEMOLITORI SELEZIONATORI  
DEMOLITION AND SORTING GRABS  
PINCES À TRIER ET À DÉMOLIR  
ABBRUCH- UND SORTIERGREIFER  
PINZAS PARA DEMOLICIÓN Y SELECCIÓN  
ГРЕЙФЕРЫ ДЛЯ РАЗРУШЕНИЯ И СОРТИРОВКИ

2

PINZE PER MOVIMENTAZIONE TRONCHI E MATERIALI VARI  
GRABS FOR LOGS' AND DIFFERENT MATERIALS' HANDLING  
PINCES POUR LA MANIPULATION DE TRONCS ET DE MATÉRIAUX DIVERS  
HOLZGREIFER UND GREIFER FÜR VERSCHIEDENEN MATERIALUMSCHLAG  
PINZAS PARA TRONCOS Y MATERIALES DIVERSOS  
ГРЕЙФЕР ДЛЯ КРУГЛОГО ЛЕСА И ДРУГИХ МАТЕРИАЛОВ

3

BENNE BIVALVE PER SCAVO E CARICO MATERIALI VARI  
GRABS FOR DIGGING AND DIFFERENT MATERIALS' LOADING  
BENNES DOUBLE-COQUILLES POUR L'EXCAVATION ET LE CHARGEMENT DE MATÉRIAUX DIVERS  
ZWEISCHALENGREIFER FÜR AUSHUB UND VERLADUNG VON VERSCHIEDENEN MATERIALIEN  
BIVALVAS PARA EXCAVACIÓN Y CARGA DE MATERIALES DIVERSOS  
ДВУХЧЕЛЮСТНОЙ ГРЕЙФЕР ДЛЯ СЫПУЧИХ МАТЕРИАЛОВ

4

ATTREZZATURE PER L'AGRICOLTURA  
EQUIPMENT FOR AGRICULTURE  
ÉQUIPEMENTS POUR L'AGRICULTURE  
AUSRÜSTUNGEN FÜR DIE LANDWIRTSCHAFT  
EQUIPOS PARA AGRICULTURA  
ОБОРУДОВАНИЕ ДЛЯ СЕЛЬСКОГО ХОЗЯЙСТВА

5

TRIVELLE  
WORM AUGERS  
TARIÈRES  
ERDBOHRER  
HOYADORAS  
ШНЕКОВЫЕ БУРЫ

6

FORCHE E PINZE PER EDILIZIA  
FORKS AND GRABS FOR THE CONSTRUCTION INDUSTRY  
FOURCHES ET PINCES POUR LE BÂTIMENT  
GABELN UND GREIFER FÜR DAS BAUGEWERBE  
HORQUILLAS Y PINZAS PARA CONSTRUCCIÓN  
ВИЛЧНЫЕ ПОГРУЗЧИКИ ПОДДОНОВ И ГРЕЙФЕРЫ ДЛЯ СТРОИТЕЛЬСТВА

7

ROTATORI IDRAULICI  
HYDRAULIC ROTATORS  
ROTATORS HYDRAULIQUES  
HYDRAULISCHE DREHMOTOREN  
ROTORES HIDRÁULICOS  
ГИДРАВЛИЧЕСКИЕ РОТАТОРЫ

8

AVVOLGITUBO  
HOSE-REEL  
ENROULEUR  
SCHLAUCHWICKLER  
ENROLLADOR DE TUBOS  
РУКАВНЫЕ КАТУШКИ

9



## BENNE A POLIPO

Le benne a polipo sono attrezzature idrauliche idonee alla movimentazione di materiali sfusi: rottame, rifiuti urbani, rifiuti industriali, scarti di lavorazione, massi, carta, cartone, plastica, legna e pneumatici. La serie RP è la versione compatta con i cilindri parzialmente inseriti all'interno delle pale per ridurre l'altezza, la serie RV è con cilindri verticali esterni fissati ad una struttura robusta. Tutti i modelli possono essere forniti con dispositivo di rotazione. La geometria delle pale è ottimizzata per favorire la penetrazione ed ottenere il massimo carico raccolto. Per soddisfare ogni esigenza e garantire elevate prestazioni con tutti i materiali, sono disponibili i tipi di pala: P - PA - S - SL. La carpenteria ed i cilindri sono realizzati con materiali di elevata qualità e resistenza mentre le parti soggette ad abrasione sono costruite in acciaio antiusura HB400. I perni e le boccole sono prodotti utilizzando acciai speciali con trattamento termico di indurimento, in modo da garantire una lunga durata anche in condizioni gravose e con scarsa lubrificazione. Cilindri con freno in apertura sono disponibili come optional per i modelli compresi dall' RV400 al RV2000 e di serie per i modelli RP502 - RP602.

## POLYP-GRABS

Polyp-grabs are hydraulic equipment suitable for the handling of bulk materials: scrap, urban waste, industrial waste, machine shop rejections, rocks, paper, cardboard, plastic, wood and tires. The RP range is the compact version with the cylinders partially inserted inside the grabs to reduce the height; the RV range has vertical outside cylinders fixed to a strong structure. Protections and guards prevent damages to pipes and cylinders. All models can be supplied with a rotation device. The geometry of the tines is optimized to promote the penetration and collect as much material as possible. To meet every need and ensure high performance with all materials, the following types of blade are available: P - PA - S - SL. The steelwork and cylinders are made with materials of high quality and durability, while the parts subject to abrasion are made of wear-resistant steel HB400. The pins and bushings are manufactured using special steel with heat treatment for hardening, so as to ensure a long life even under severe conditions and with poor lubrication. On grabs for loaders/excavators (RV400 → RV2000) we can supply cylinders with a brake as optional (they're standard on the models RP502 - RP602).

## GRAPPINS

Les grappins sont des équipements hydrauliques adaptés à la manipulation de matériaux divers : ferrailles, ordures, déchets industriels, déchets d'usage, roches, papier, carton, plastique, bois et pneus. La série RP est la version compacte avec des vérins intégrés dans les dents ; la série RV est la version avec des vérins verticaux externes fixés à la structure de grappin. Des carters et des protections évitent des dommages au niveau des flexibles et des vérins. Tous les modèles peuvent être livrés avec un dispositif de rotation. La forme des coquilles est optimisée pour favoriser la pénétration et recueillir autant de matériel que possible. Pour répondre à tous les besoins et assurer une haute performance avec tous les matériaux, sont disponibles les types de coquilles suivants: P - PA - S - SL. La structure et les vérins sont fabriqués avec des matériaux de haute qualité et de durabilité, tandis que les pièces sujettes à l'usure sont en acier anti-usure Hardox HB400. Les axes et les bagues sont réalisés en acier spécial à l'aide d'un traitement thermique de durcissement, de manière à assurer une longue durée de vie même dans des conditions difficiles et avec une mauvaise lubrification. Sur les équipements pour pelles (RV400 → RV2000) les vérins avec freins à l'ouverture, sont disponibles en option (standard pour les modèles RP502 - RP602).

## POLYPGREIFER



Polypgreifer sind hydraulische Ausrüstungen für den Umschlag von losem Material : Schrott, Hausabfälle, Industrieabfälle, Verarbeitungsabfälle, Gestein, Papier, Pappe, Plaste, Holz und Reifen. Die Serie RP ist eine kompakte Ausführung mit zum Teil in die Schalen eingelassenen Zylindern zur Reduzierung der Bauhöhe. Die Serie RV hat außen liegende Zylinder. Der angebrachte Zylinderschutz vermeidet Beschädigungen am Zylinder und an der Verrohrung. Alle Modelle können mit Drehmotoren ausgestattet werden. Die Anordnung der Schalen ermöglicht eine maximale Aufnahme von Material. Um allen Anforderungen gerecht zu werden, sind Schalen in den unterschiedlichsten Ausführungen verfügbar: P-PA-S-SL. Die Stahlkonstruktion und die Zylinder werden aus hochwertigem Material gefertigt und die Teile, die einem besonders starken Abrieb ausgesetzt sind, bestehen aus verschleißfestem Stahl HB 400. Die Bolzen und Buchsen sind aus Spezialstahl mit thermischer Härtebehandlung, um auch unter schwierigsten Einsatzbedingungen und trotz unzureichender Schmierung eine lange Lebensdauer zu gewährleisten. Greifer für Lader und Bagger ( RV 400 → RV 2000) sind als Option mit Zylinderbremsen beim Öffnen der Greifer ausgestattet (für die Modelle RP 502 - RP 602 in Serie).



## PULPOS

Los pulpos son equipos hidráulicos que sirven para mover materiales como basuras, desperdicios domésticos e industriales, runas, rocas, papel, cartón, plástico, madera y neumáticos. La serie RP es la versión compacta, donde los cilindros van incrustados parcialmente al interior de las palas y así poder reducir su altura; la serie RV incorpora los cilindros verticales en la parte exterior de su estructura. Dichos equipos están equipados con cárteres y diversas protecciones que evitan daños externos a tuberías y cilindros. Todos los modelos se pueden encontrar con dispositivos de rotación. La disposición de las palas está diseñada para optimizar la penetración en los materiales y abarcar la mayor cantidad posible. Para satisfacer cualquier exigencia y asegurar sus óptimas prestaciones para los distintos materiales, se pueden elegir distintos modelos de pala en función del residuo a tratar, son: P-PA-S-SL. La fabricación de los cilindros está hecha con materiales de calidad y resistencia, de tal manera que, los elementos expuestos a desgaste por abrasión están fabricados con acero para evitar su abrasión, como el HB400. Pernos y cajas del eje están hechos con aceros especiales con tratamiento térmico de endurecimiento con el fin de garantizar una larga durabilidad incluso en situaciones de sequedad y poca lubricación. Existen como accesorio para los equipos RV400 → RV2000, los cilindros con freno de apertura, equipados de serie en los modelos RP502 y RP602.



## МНОГОЧЕЛЮСТНЫЕ ГРЕЙФЕРЫ

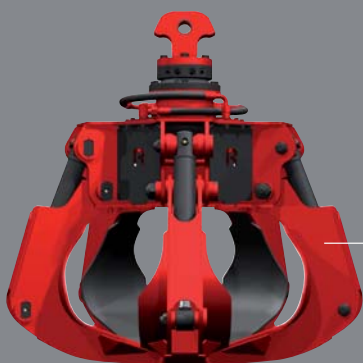
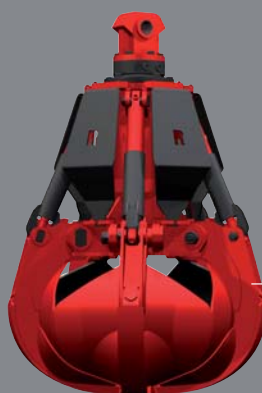
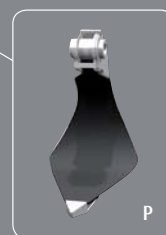
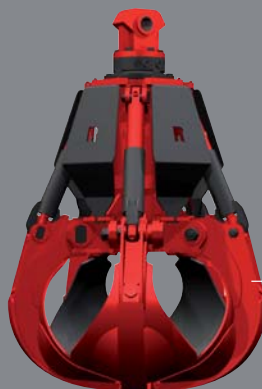
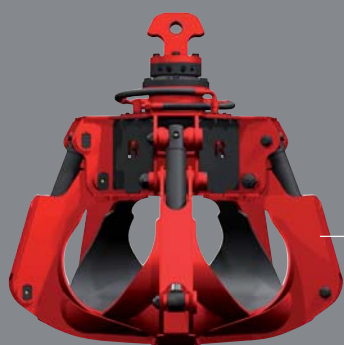

Многочелюстные грейферы – гидравлическое оборудование, предназначенное для перевалки сыпучих материалов: металлолом, городской мусор, промышленные отходы, камни, бумага, картон, пластик, дерево и колеса. Серия RP является компактной версией, в которой цилиндр частично находится внутри грейфера, чтобы уменьшить его высоту. В серии RV вертикальный цилиндр прикручен к жесткому каркасу. Защита предотвращает повреждение труб и цилиндров. Все модели могут быть оснащены ротатором. Форма лепестков сконструирована таким образом, чтобы захватывать как можно больше материала. Чтобы соответствовать всем требованиям и обеспечивать надежный захват всех материалов, существуют следующие типы лепестков: P - PA - S - SL. Стальная конструкция и цилиндры выполнены из высококачественных износостойких материалов, в то время как части, подверженные износу, выполнены из износостойкой стали HB400. Пальцы и втулки сделаны из специальной закаленной стали, которые долго служат даже при тяжелых условиях и при недостатке смазки. На грейферы для погрузчиков/экскаваторов (RV400 → RV2000) мы можем поставлять цилиндры с тормозом в качестве опции (на моделях RP502 - RP602 это является стандартом).

 Versioni di pale  
 Tines versions  
 Versions coquilles



 Schalentypen  
 Modelos de pala  
 Форма лепестков



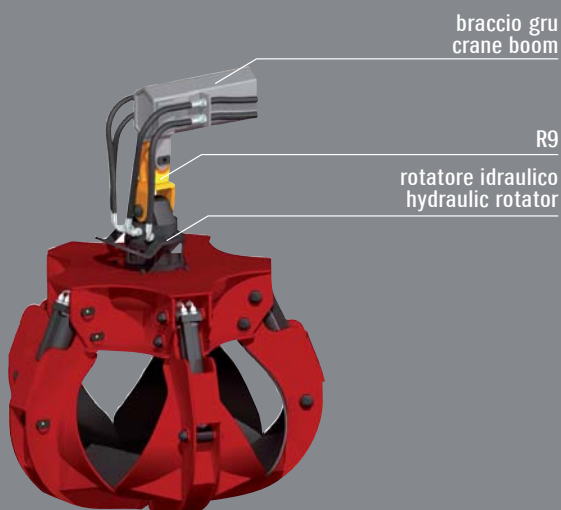
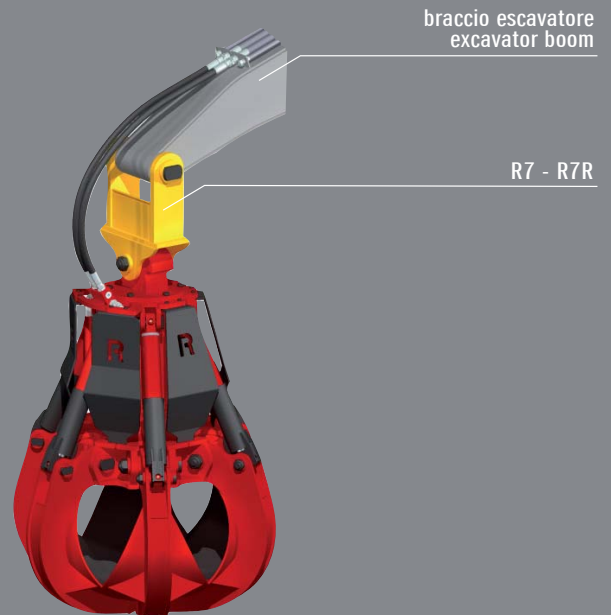
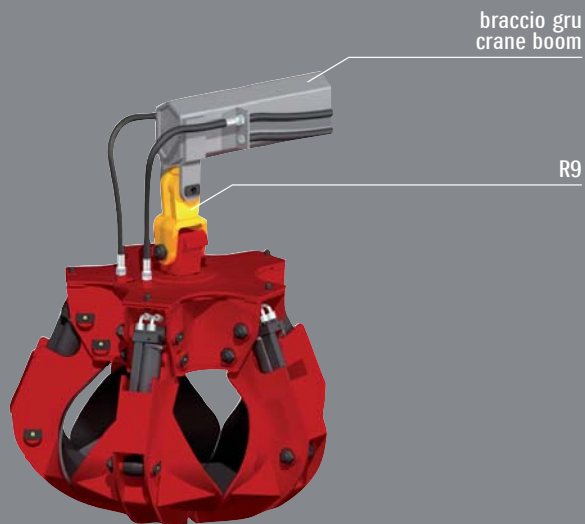
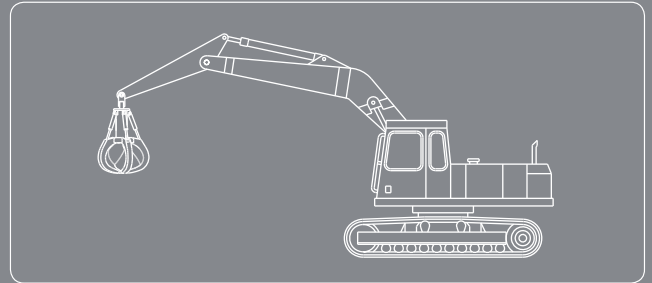
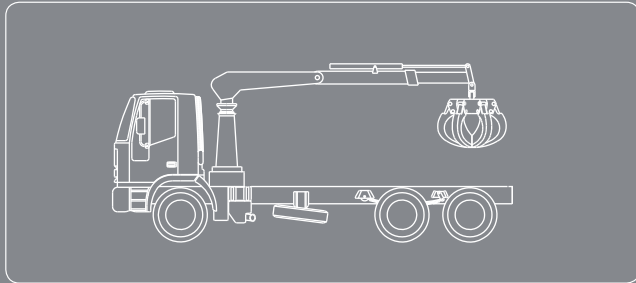

 Esempi di applicazione  
 Examples of application  
 Exemples d'application



 Anwendungsbeispiele  
 Ejemplos de aplicacion  
 Примеры комплектации





 Schema di utilizzo per benne a polipo  
 Scheme of use for polyp-grabs  
 Schéma d'emploi pour grappins

 Anwendungsübersicht für Mehrschalengreifer  
 Esquema de uso para pulpos  
 Схема использования полип-грейферов

Benne a polipo Polyp-grabs	Gancio Hook	Giunto idraulico Free rotator	Rotatore idraulico Hydraulic rotator	Peso escavatore / caricatore Excavator / loader weight
RP120 - RV130	R9	***	R102 - R103	2 - 4
RV180 - RP180	R9	***	R103 - R104	3 - 6
RV230 - RP230	R9	***	R104 - R05 - R105	5 - 8
RV250 - RP250 - RP280	R9	***	R05 - R105	6 - 9
RTG250 - RTG300	R9	***	R05 - R105 - R105H	***
RV300 - RP300	R9	***	R05 - R105 - R105H	8 - 11
RV280 - RV320	R9 - R7	R2	R05 - R105H - R1G	8 - 14
RP350	R7	R2 - R2IR10	R3IR - R1G	11 - 16
RV400B	R7 - R7R	R2 - R2A - R2IR10	R3IR - R1G - R4G	15 - 20
RP500A	R7 - R7R	R2 - R2A - R2IR10	R3IR - R1G - R4G	15 - 20
RV500A	R7 - R7R	R2A - R2IR10	R3IR - R4G	18 - 23
RP502	R7 - R7R	R2A - R2IR10	R3IR - R3BIR - R4G	18 - 23
RP602	R7 - R7R	R2A - R2IR10 - R2BIR20	R3IR - R3BIR - R4G	19 - 24
RV550	R7R	R2A - R2BIR20	R3BIR - R4G	22 - 28
RV600A	R7R	R2A - R2BIR20	R3BIR - R4G	23 - 30
RV800A	R7R	R2BIR20	R3BIR - R4G	24 - 32
RV1000	R7R	R2C	R3C	30 - 40
RV1250C	R7R	R2C	R3C - R5G	32 - 40
RV1500C	R7R	R2C	R5G	35 - 45
RV2000C	R7R	***	R5G	35 - 45
RR360	R9	***	R104 - R05 - R105	6 - 9
RR560	R7	R2	R05 - R105H - R1G	9 - 15
RR650A	R7 - R7R	R2 - R2A - R2IR10	R3IR - R1G - R4G	15 - 20
RR700	R7 - R7R	R2A - R2IR10 - R2BIR20	R3IR - R3BIR - R4G	19 - 24
RR800	R7 - R7R	R2A - R2IR10	R3IR - R4G	18 - 23
RR1100	R7R	R2BIR20	R3BIR - R4G	23 - 32
RVM250	R9	***	R105HA	8 - 11
RVM350	R7 - R7R	***	R1G - R4G	12 - 19
RVM500	R7R	***	R4G	19 - 24
RM400	R7	R2 - R2IR10	R1G - R3IR	12 - 17
RM601	R7R	R2A - R2BIR20	R3BIR - R4G	18 - 24
RM901	R7R	R2C	R3C - R5G	26 - 40

 Benna a polipo per movimentazione rottame e materiali vari  
 Polyp-grab for scrap's and different materials' handling  
 Grappin pour la manipulation de la ferraille et de matériaux divers

 Mehrschalengreifer für Schrott-und verschiedenen Materialumschlag  
 Pulpos para chatarra y materiales diversos  
 Полип – грейфер для загрузки металлолома и различных материалов

&gt; RP120



&gt; RP230





&gt; RP180



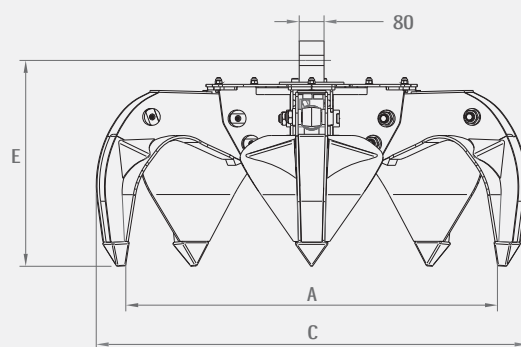
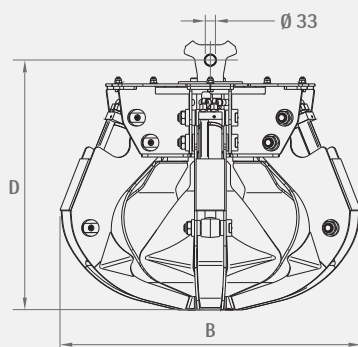
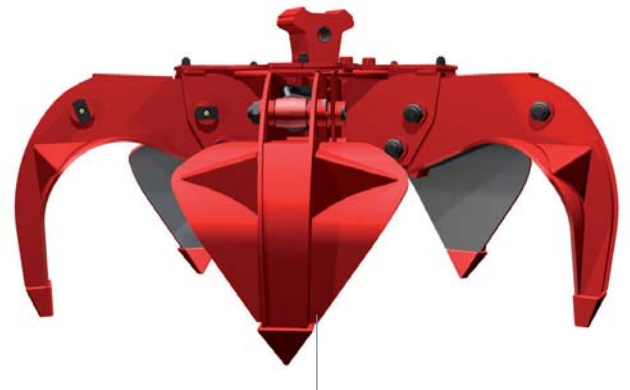

&gt; RP230



Modello	Capacità	Peso	Denti n°	Pressione	Portata olio	Forza al dente	Dimensioni				
Model	Capacity	Weight	Teeth no.	Pressure	Oil flow	Tooth force	Sizes				
Modèle	Capacité	Poids	Dents n.	Pression	Débit d'huile	Puissance à la dent	Dimensions				
Modell	Inhalt	Gewicht	Zähne Stk.	Druck	Ölleistung	Schließkraft je Schale	Abmessungen				
	dm <sup>3</sup>	kg	n°	bar	l/min	Kg	A	B	C	D	E
RP120	120	130	4	250	30	610	1170	805	1250	965	565
RP180	180	220	5	280	50	1015	1250	950	1400	795	650
RP230	230	300	5	280	70	1330	1260	1000	1440	810	670

 Benna a polipo per movimentazione rottame e materiali vari  
 Polyp-grab for scrap's and different materials' handling  
 Grappin pour la manipulation de la ferraille et de matériaux divers

 Mehrschalengreifer für Schrott-und verschiedenen Materialumschlag  
 Pulpos para chatarra y materiales diversos  
 Полип – грейфер для погрузки металлолома и различных материалов

> RV130



> RV250



> RV180



> RGN300D



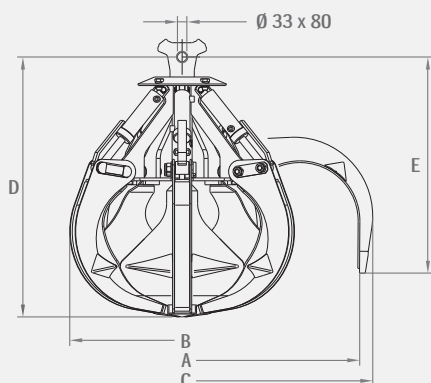

> RV



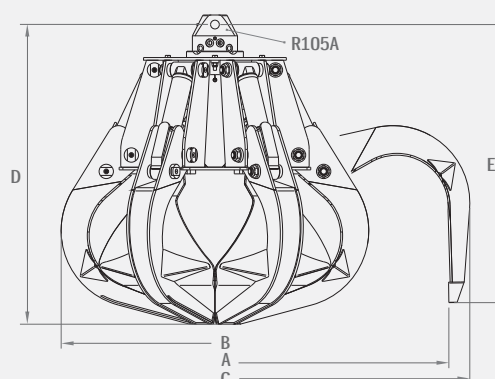

> RG



Modello	Capacità	Peso	Denti n°	Pressione	Portata olio	Forza al dente	Dimensioni				
Model	Capacity	Weight	Teeth no.	Pressure	Oil flow	Tooth force	Sizes				
Modèle	Capacité	Poids	Dents n.	Pression	Débit d'huile	Puissance à la dent	Dimensions				
Modell	Inhalt	Gewicht	Zähne Stk.	Druck	Ölleistung	Schließkraft je Schale	Abmessungen				
	dm <sup>3</sup>	kg	n°	bar	l/min	Kg	A	B	C	D	E
<b>RV130</b>	130	145	5	250	30	520	1250	790	1350	900	730
<b>RV180</b>	180	180	5	250	50	750	1410	870	1500	910	760
<b>RV230</b>	230	270	5	280	70	1230	1330	940	1450	1050	890
<b>RV250</b>	250	360	6	280	90	1150	1470	1060	1650	1090	980
<b>RVN300</b>	300	460	6	280	90	1320	1570	1160	1730	1060	930
<b>RGN300D</b>	300	510	6	280	90	1320	1570	1160	1730	1130	1000

 Benna a polipo per movimentazione rottame e materiali vari  
 Polyp-grab for scrap's and different materials' handling  
 Grappin pour la manipulation de la ferraille et de matériaux divers

 Mehrschalengreifer für Schrott-und verschiedenen Materialumschlag  
 Pulpos para chatarra y materiales diversos  
 Полип – грейфер для погрузки металлолома и различных материалов

> RP250 4P



> RP250 6P  
> RP280 6P



> RP250 5P





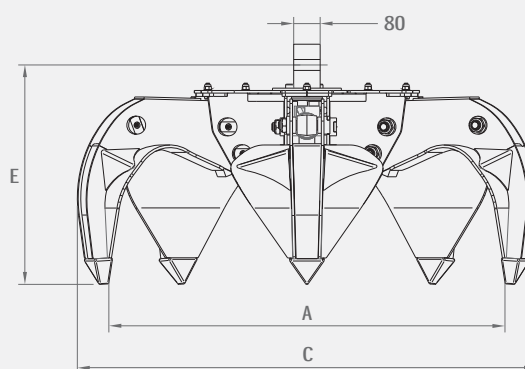
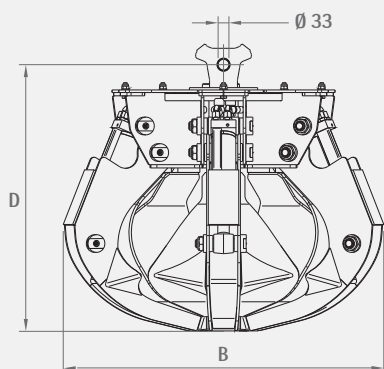



> RP250 5P



Modello	Capacità	Peso	Denti n°	Pressione	Portata olio	Forza al dente	Dimensioni				
Model	Capacity	Weight	Teeth no.	Pressure	Oil flow	Tooth force	Sizes				
Modèle	Capacité	Poids	Dents n.	Pression	Débit d'huile	Puissance à la dent	Dimensions				
Modell	Inhalt	Gewicht	Zähne Stk.	Druck	Ölleistung	Schließkraft je Schale	Abmessungen				
	dm <sup>3</sup>	kg	n°	bar	l/min	Kg	A	B	C	D	E
RP250 4P	250	310	4	280	60	1160	1420	1080	1630	870	740
RP250 5P	250	350	5	280	70	1160	1420	1080	1630	870	740
RP250 6P	250	390	6	280	80	1160	1420	1080	1630	870	740
RP280 6P	280	410	6	280	80	1080	1510	1110	1710	920	760



 Benna a polipo per movimentazione rottame e materiali vari  
 Polyp-grab for scrap's and different materials' handling  
 Grappin pour la manipulation de la ferraille et de matériaux divers

 Mehrschalengreifer für Schrott-und verschiedenen Materialumschlag  
 Pulpos para chatarra y materiales diversos  
 Полип – грейфер для погрузки металлолома и различных материалов

> RP300 4P



> RP300 6P





> RP300 5P



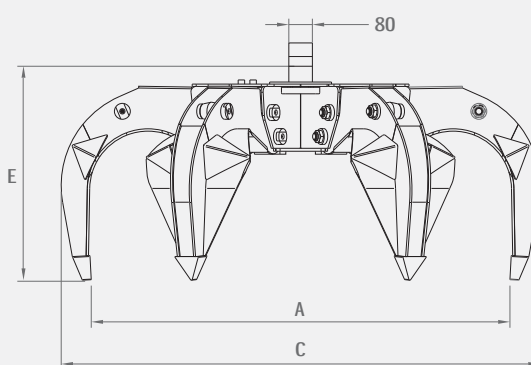
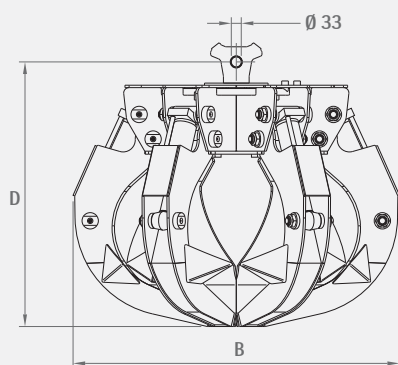

> RP300 5P



Modello	Capacità	Peso	Denti n°	Pressione	Portata olio	Forza al dente	Dimensioni				
Model	Capacity	Weight	Teeth no.	Pressure	Oil flow	Tooth force	Sizes				
Modèle	Capacité	Poids	Dents n.	Pression	Débit d'huile	Puissance à la dent	Dimensions				
Modell	Inhalt	Gewicht	Zähne Stk.	Druck	Ölleistung	Schließkraft je Schale	Abmessungen				
	dm <sup>3</sup>	kg	n°	bar	l/min	Kg	A	B	C	D	E
<b>RP300 4P</b>	300	400	4	280	70	1220	1630	1210	1850	960	810
<b>RP300 5P</b>	300	450	5	280	80	1220	1630	1210	1850	960	810
<b>RP300 6P</b>	300	500	6	280	90	1220	1630	1210	1850	960	810

 Benna a polipo per movimentazione rottame e materiali vari  
 Polyp-grab for scrap's and different materials' handling  
 Grappin pour la manipulation de la ferraille et de matériaux divers

 Mehrschalengreifer für Schrott-und verschiedenen Materialumschlag  
 Pulpos para chatarra y materiales diversos  
 Полип – грейфер для погрузки металлолома и различных материалов

› RHG250A 5P



› RHG250A  
› RHG280A

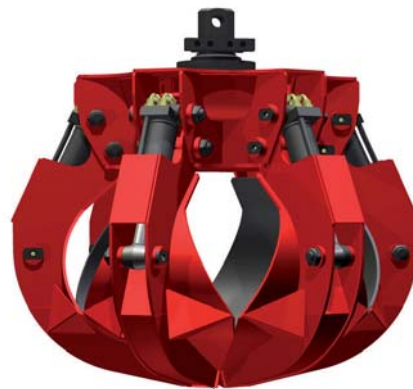

› RHG250D 5P



› RHG250D  
› RHG280D



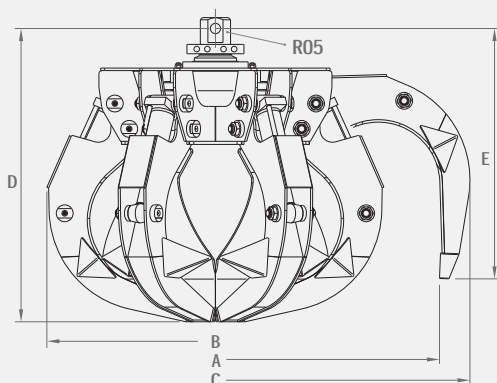

› RHGA



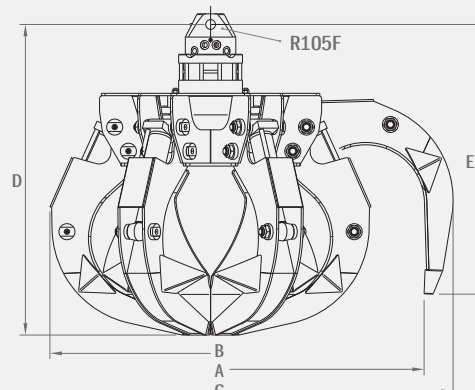

› RHG D



Modello	Capacità	Peso	Denti n°	Pressione	Portata olio	Forza al dente	Dimensioni				
Model	Capacity	Weight	Teeth no.	Pressure	Oil flow	Tooth force	Sizes				
Modèle	Capacité	Poids	Dents n.	Pression	Débit d'huile	Puissance à la dent	Dimensions				
Modell	Inhalt	Gewicht	Zähne Stk.	Druck	Ölleistung	Schließkraft je Schale	Abmessungen				
	dm <sup>3</sup>	kg	n°	bar	l/min	Kg	A	B	C	D	E
RHG250A 5P	250	420	5	280	70	1160	1420	1080	1630	940	810
RHG250D 5P	250	440	5	280	70	1160	1420	1080	1630	1030	900
RHG250A	250	430	6	280	80	1160	1420	1080	1630	940	810
RHG250D	250	450	6	280	80	1160	1420	1080	1630	1030	900
RHG280A	280	450	6	280	80	1080	1510	1110	1710	990	830
RHG280D	280	470	6	280	80	1080	1510	1110	1710	1080	920

 Benna a polipo per movimentazione rottame e materiali vari  
 Polyp-grab for scrap's and different materials' handling  
 Grappin pour la manipulation de la ferraille et de matériaux divers

 Mehrschalengreifer für Schrott-und verschiedenen Materialumschlag  
 Pulpos para chatarra y materiales diversos  
 Полип – грейфер для погрузки металлолома и различных материалов

> RHG300A 5P

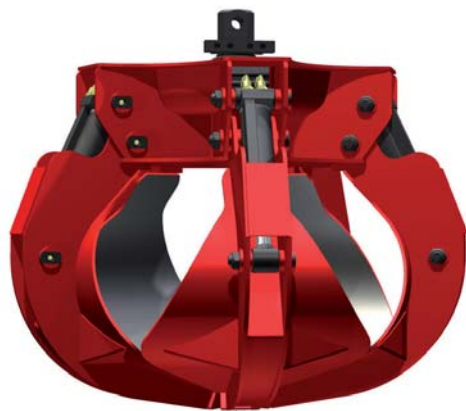

> RHG300A



> RHG300D 5P



> RHG300D



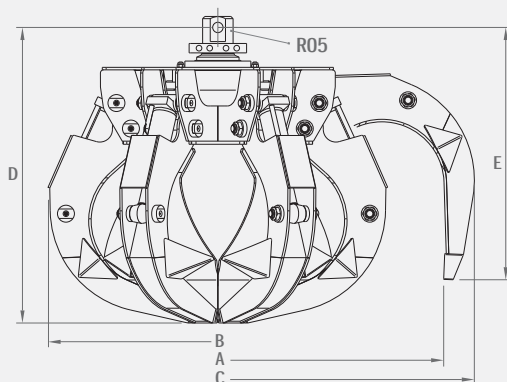

> RHG A



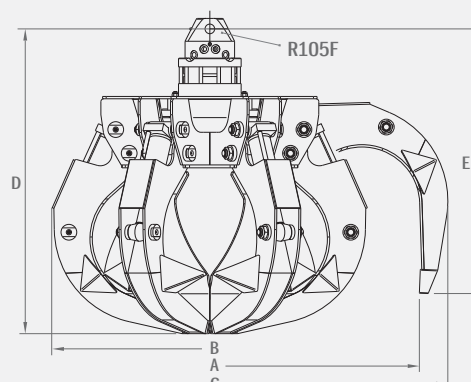

> RHG D





Modello	Capacità	Peso	Denti n°	Pressione	Portata olio	Forza al dente	Dimensioni				
Model	Capacity	Weight	Teeth no.	Pressure	Oil flow	Tooth force	Sizes				
Modèle	Capacité	Poids	Dents n.	Pression	Débit d'huile	Puissance à la dent	Dimensions				
Modell	Inhalt	Gewicht	Zähne Stk.	Druck	Ölleistung	Schließkraft je Schale	Abmessungen				
	dm <sup>3</sup>	kg	n°	bar	l/min	Kg	A	B	C	D	E
RHG300A 5P	300	480	5	280	80	1220	1630	1210	1850	1010	860
RHG300D 5P	300	500	5	280	80	1220	1630	1210	1850	1100	950
RHG300A	300	530	6	280	90	1220	1630	1210	1850	1010	860
RHG300D	300	550	6	280	90	1220	1630	1210	1850	1100	950

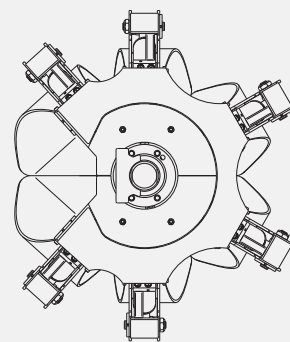
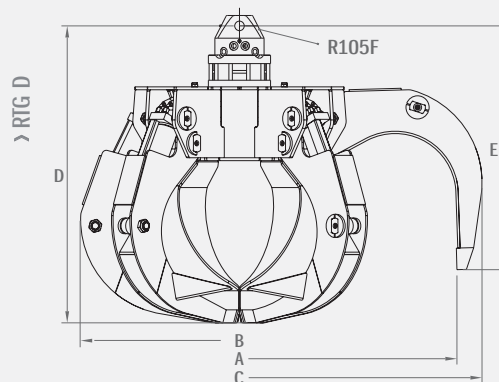
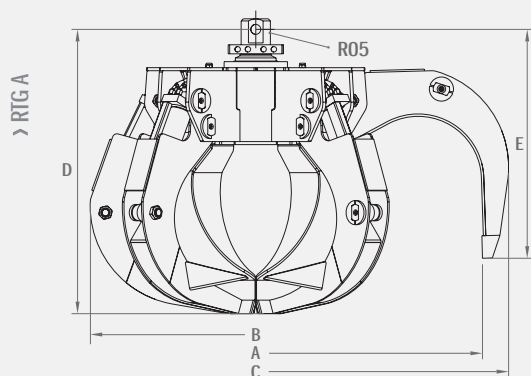
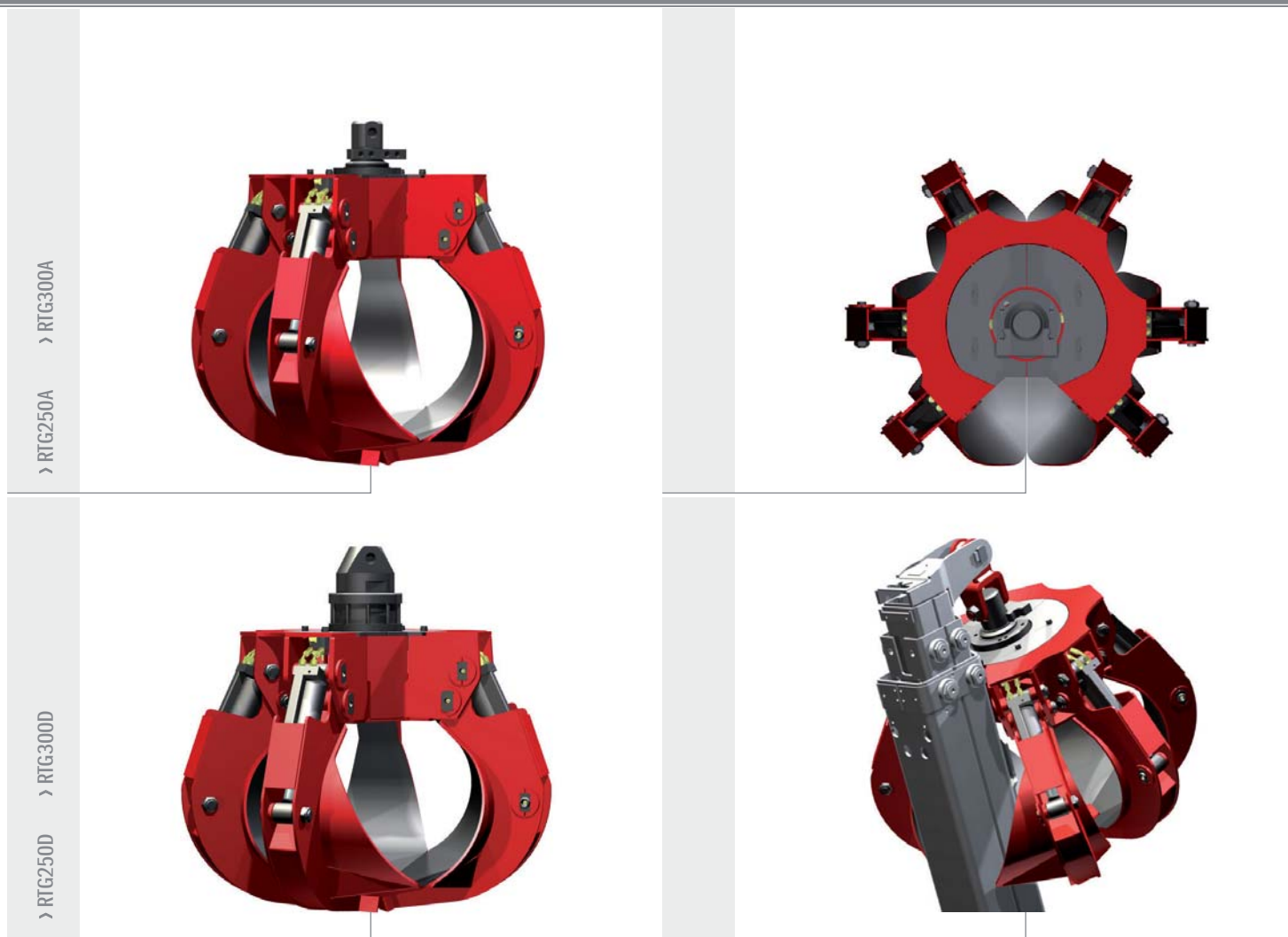

 Benna a polipo per movimentazione rottame e materiali vari  
 Polyp-grab for scrap's and different materials' handling  
 Grappin pour la manipulation de la ferraille et de matériaux divers

 Mehrschalengreifer für Schrott-und verschiedenen Materialumschlag  
 Pulpos para chatarra y materiales diversos  
 Полип – грейфер для погрузки металлолома и различных материалов



Modello	Capacità	Peso	Denti n°	Pressione	Portata olio	Forza al dente	Dimensioni				
Model	Capacity	Weight	Teeth no.	Pressure	Oil flow	Tooth force	Sizes				
Modèle	Capacité	Poids	Dents n.	Pression	Débit d'huile	Puissance à la dent	Dimensions				
Modell	Inhalt	Gewicht	Zähne Stk.	Druck	Ölleistung	Schließkraft je Schale	Abmessungen				
	dm <sup>3</sup>	kg	n°	bar	l/min	Kg	A	B	C	D	E
RTG250A	250	440	6	300	80	1260	1500	1100	1680	950	760
RTG250D	250	460	6	300	80	1260	1500	1100	1680	1030	840
RTG300A	300	460	6	300	80	1130	1650	1110	1815	1020	790
RTG300D	300	480	6	300	80	1130	1650	1110	1815	1100	870

 Benna a polipo per movimentazione rottame e materiali vari  
 Polyp-grab for scrap's and different materials' handling  
 Grappin pour la manipulation de la ferraille et de matériaux divers

 Mehrschalengreifer für Schrott-und verschiedenen Materialumschlag  
 Pulpos para chatarra y materiales diversos  
 Полип – грейфер для погрузки металлолома и различных материалов

> RV280 5P



> RV320 5P





> RV280 6P



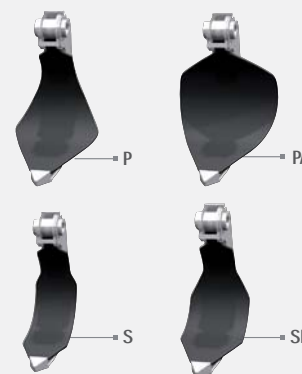
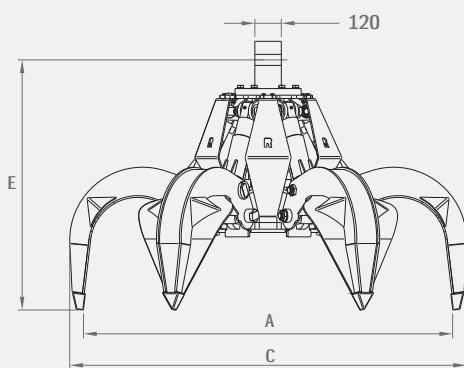
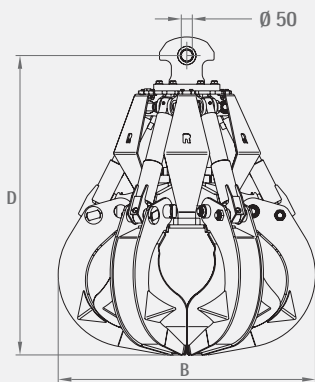

> RV320 6P





Modello	Capacità	Peso	Denti n°	Pressione	Portata olio	Forza al dente	Dimensioni				
Model	Capacity	Weight	Teeth no.	Pressure	Oil flow	Tooth force	Sizes				
Modèle	Capacité	Poids	Dents n.	Pression	Débit d'huile	Puissance à la dent	Dimensions				
Modell	Inhalt	Gewicht	Zähne Stk.	Druck	Ölleistung	Schließkraft je Schale	Abmessungen				
	dm <sup>3</sup>	kg	n°	bar	l/min	Kg	A	B	C	D	E
RV280 5P	280	580	5	300	90	1650	1600	1090	1720	1270	1080
RV280 6P	280	640	6	300	110	1650	1600	1090	1720	1270	1080
RV320 5P	320	620	5	300	90	1550	1680	1170	1800	1320	1100
RV320 6P	320	680	6	300	110	1550	1680	1170	1800	1320	1100

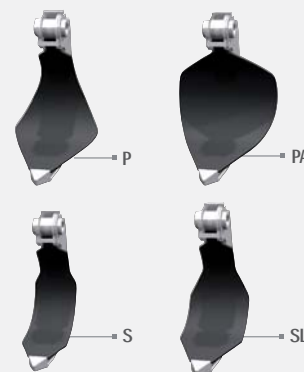
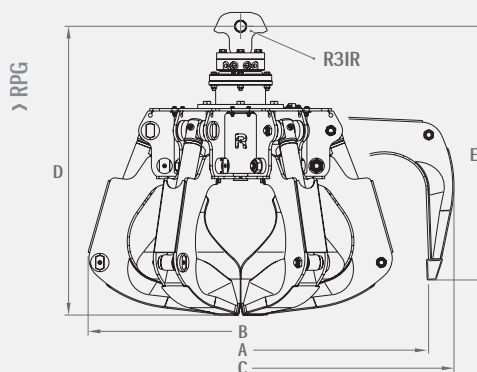
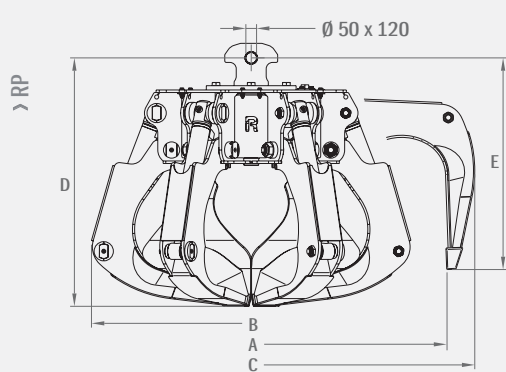

 Benna a polipo per movimentazione rottame e materiali vari  
 Polyp-grab for scrap's and different materials' handling  
 Grappin pour la manipulation de la ferraille et de matériaux divers

 Mehrschalengreifer für Schrott-und verschiedenen Materialumschlag  
 Pulpos para chatarra y materiales diversos  
 Полип – грейфер для погрузки металлолома и различных материалов





Modello	Capacità	Peso	Denti n°	Pressione	Portata olio	Forza al dente	Dimensioni				
Model	Capacity	Weight	Teeth no.	Pressure	Oil flow	Tooth force	Sizes				
Modèle	Capacité	Poids	Dents n.	Pression	Débit d'huile	Puissance à la dent	Dimensions				
Modell	Inhalt	Gewicht	Zähne Stk.	Druck	Ölleistung	Schließkraft je Schale	Abmessungen				
	dm <sup>3</sup>	kg	n°	bar	l/min	Kg	A	B	C	D	E
RP350 6P	350	730	6	300	120	1750	1780	1320	1990	1130	870
RPG350 6P	350	880	6	300	120	1750	1780	1320	1990	1410	1130
RP500A 5P	500	860	5	320	120	2540	1830	1490	2100	1165	995
RP500A 6P	500	960	6	320	160	2540	1830	1490	2100	1165	995
RPG500A 5P	500	1060	5	320	120	2540	1830	1490	2100	1415	1245
RPG500A 6P	500	1160	6	320	160	2540	1830	1490	2100	1415	1245

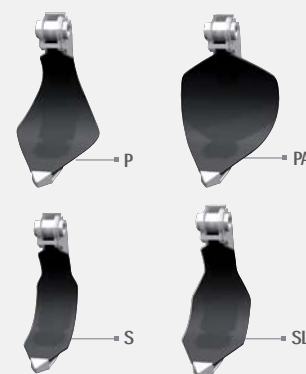
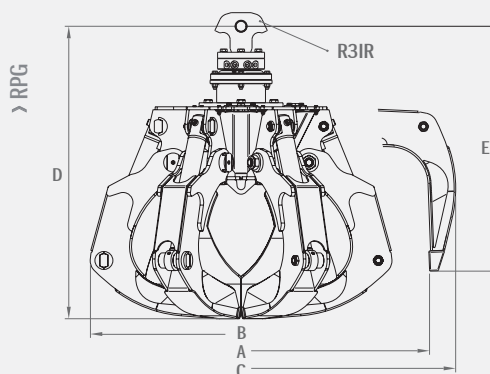
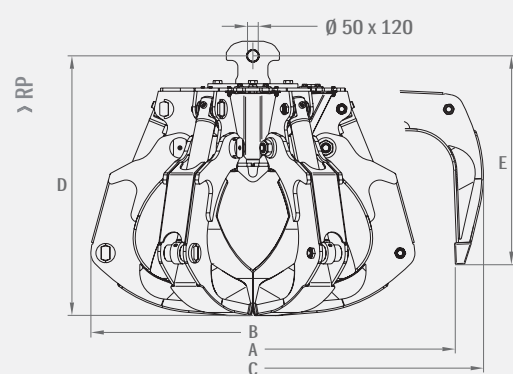

 Benna a polipo per movimentazione rottame e materiali vari  
 Polyp-grab for scrap's and different materials' handling  
 Grappin pour la manipulation de la ferraille et de matériaux divers

 Mehrschalengreifer für Schrott-und verschiedenen Materialumschlag  
 Pulpos para chatarra y materiales diversos  
 Полип – грейфер для погрузки металлолома и различных материалов



Modello	Capacità	Peso	Denti n°	Pressione	Portata olio	Forza al dente	Dimensioni				
Model	Capacity	Weight	Teeth no.	Pressure	Oil flow	Tooth force	Sizes				
Modèle	Capacité	Poids	Dents n.	Pression	Débit d'huile	Puissance à la dent	Dimensions				
Modell	Inhalt	Gewicht	Zähne Stk.	Druck	Ölleistung	Schließkraft je Schale	Abmessungen				
	dm <sup>3</sup>	kg	n°	bar	l/min	Kg	A	B	C	D	E
RP502 5P	500	980	5	320	160	2935	1890	1515	2150	1210	970
RP502 6P	500	1100	6	320	190	2935	1890	1515	2150	1210	970
RPG502 5P	500	1130	5	320	160	2935	1890	1515	2150	1520	1280
RPG502 6P	500	1250	6	320	190	2935	1890	1515	2150	1520	1280



 Benna a polipo per movimentazione rottame e materiali vari  
 Polyp-grab for scrap's and different materials' handling  
 Grappin pour la manipulation de la ferraille et de matériaux divers

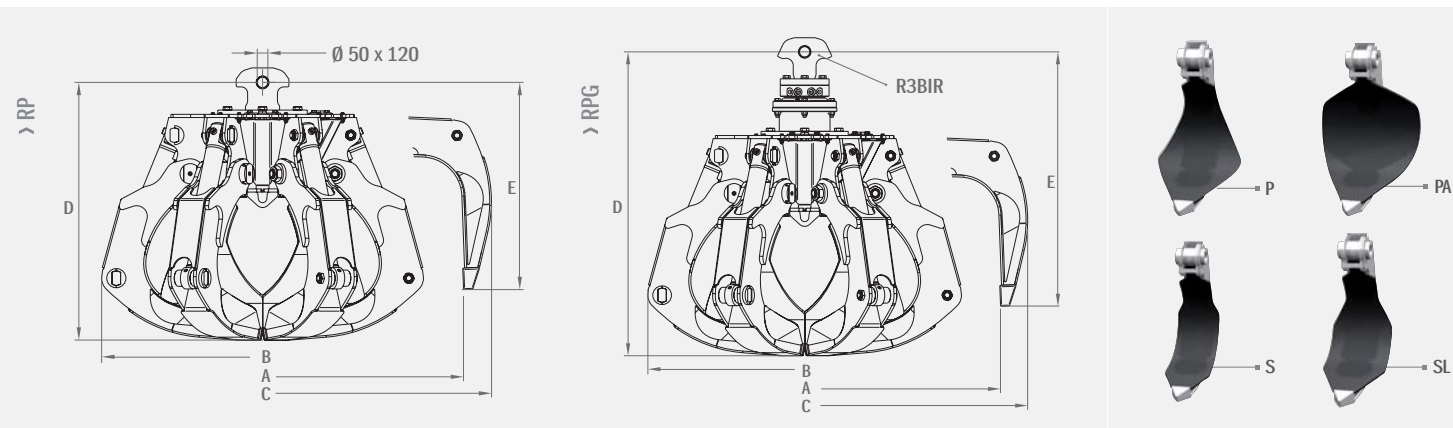

 Mehrschalengreifer für Schrott-und verschiedenen Materialumschlag  
 Pulpos para chatarra y materiales diversos  
 Полип – грейфер для погрузки металлолома и различных материалов



Modello	Capacità	Peso	Denti n°	Pressione	Portata olio	Forza al dente	Dimensioni				
Model	Capacity	Weight	Teeth no.	Pressure	Oil flow	Tooth force	Sizes				
Modèle	Capacité	Poids	Dents n.	Pression	Débit d'huile	Puissance à la dent	Dimensions				
Modell	Inhalt	Gewicht	Zähne Stk.	Druck	Ölleistung	Schließkraft je Schale	Abmessungen				
	dm <sup>3</sup>	kg	n°	bar	l/min	Kg	A	B	C	D	E
RP602 5P	600	1010	5	320	160	2690	2045	1515	2285	1295	1000
RP602 6P	600	1130	6	320	190	2690	2045	1515	2285	1295	1000
RPG602 5P	600	1160	5	320	160	2690	2045	1515	2285	1600	1300
RPG602 6P	600	1280	6	320	190	2690	2045	1515	2285	1600	1300



 Benna a polipo per movimentazione rottame e materiali vari  
 Polyp-grab for scrap's and different materials' handling  
 Grappin pour la manipulation de la ferraille et de matériaux divers

 Mehrschalengreifer für Schrott-und verschiedenen Materialumschlag  
 Pulpos para chatarra y materiales diversos  
 Полип – грейфер для погрузки металлолома и различных материалов

> RV400 5P



> RV400 6P



> RVG400 6P



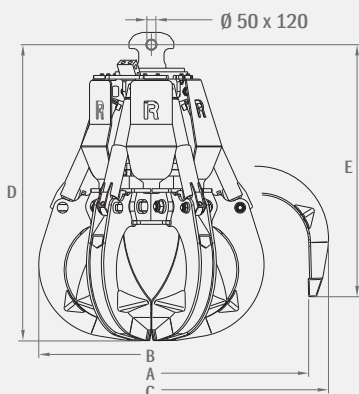

> RV



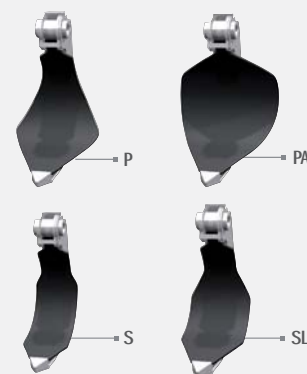
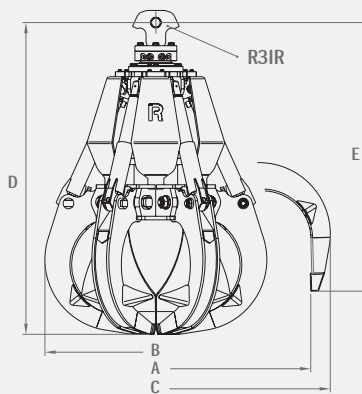

> RVG



Modello	Capacità	Peso	Denti n°	Pressione	Portata olio	Forza al dente	Dimensioni				
Model	Capacity	Weight	Teeth no.	Pressure	Oil flow	Tooth force	Sizes				
Modèle	Capacité	Poids	Dents n.	Pression	Débit d'huile	Puissance à la dent	Dimensions				
Modell	Inhalt	Gewicht	Zähne Stk.	Druck	Ölleistung	Schließkraft je Schale	Abmessungen				
	dm <sup>3</sup>	kg	n°	bar	l/min	Kg	A	B	C	D	E
<b>RV400B 5P</b>	400	930	5	300	120	2150	1750	1240	1960	1620	1370
<b>RV400B 6P</b>	400	1020	6	300	140	2150	1750	1240	1960	1620	1370
<b>RVG400B 5P</b>	400	1000	5	300	120	2150	1750	1240	1960	1750	1510
<b>RVG400B 6P</b>	400	1090	6	300	140	2150	1750	1240	1960	1750	1510

 Benna a polipo per movimentazione rottame e materiali vari  
 Polyp-grab for scrap's and different materials' handling  
 Grappin pour la manipulation de la ferraille et de matériaux divers

 Mehrschalengreifer für Schrott-und verschiedenen Materialumschlag  
 Pulpos para chatarra y materiales diversos  
 Полип – грейфер для погрузки металлолома и различных материалов

> RV500 5P



> RV500 6P



> RVG500 6P



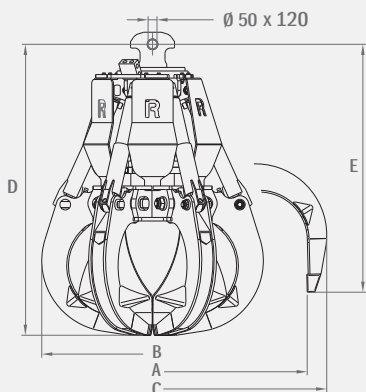

> RV



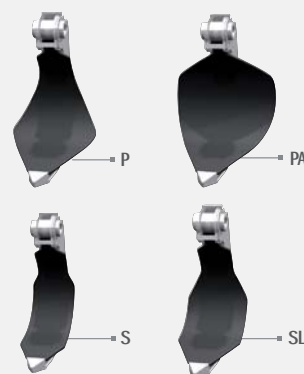
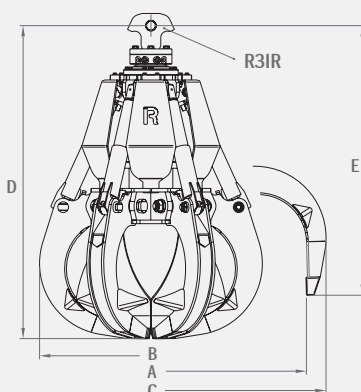

> RVG



Modello	Capacità	Peso	Denti n°	Pressione	Portata olio	Forza al dente	Dimensioni				
Model	Capacity	Weight	Teeth no.	Pressure	Oil flow	Tooth force	Sizes				
Modèle	Capacité	Poids	Dents n.	Pression	Débit d'huile	Puissance à la dent	Dimensions				
Modell	Inhalt	Gewicht	Zähne Stk.	Druck	Ölleistung	Schließkraft je Schale	Abmessungen				
	dm <sup>3</sup>	kg	n°	bar	l/min	Kg	A	B	C	D	E
RV500A 5P	500	1140	5	300	160	2750	1930	1320	2140	1780	1470
RV500A 6P	500	1240	6	300	180	2750	1930	1320	2140	1780	1470
RVG500A 5P	500	1200	5	300	160	2750	1930	1320	2140	1905	1600
RVG500A 6P	500	1300	6	300	180	2750	1930	1320	2140	1905	1600

 Benna a polipo per movimentazione rottame e materiali vari  
 Polyp-grab for scrap's and different materials' handling  
 Grappin pour la manipulation de la ferraille et de matériaux divers

 Mehrschalengreifer für Schrott-und verschiedenen Materialumschlag  
 Pulpos para chatarra y materiales diversos  
 Полип – грейфер для погрузки металлолома и различных материалов

> RV550 5P



> RV550 6P



> RVG550 5P



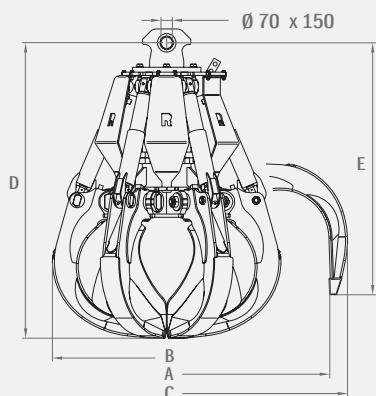

> RV



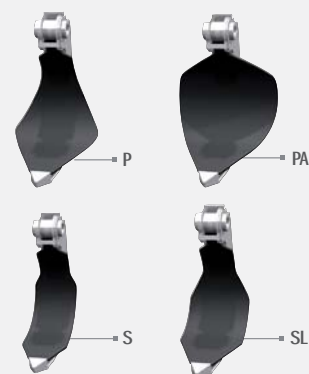
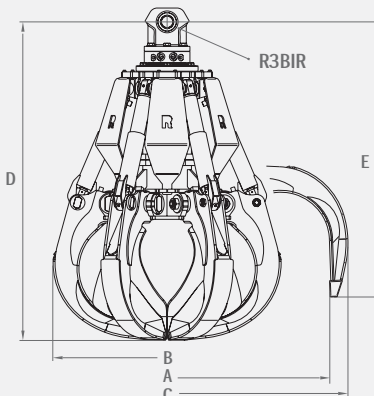

> RVG



Modello	Capacità	Peso	Denti n°	Pressione	Portata olio	Forza al dente	Dimensioni				
Model	Capacity	Weight	Teeth no.	Pressure	Oil flow	Tooth force	Sizes				
Modèle	Capacité	Poids	Dents n.	Pression	Débit d'huile	Puissance à la dent	Dimensions				
Modell	Inhalt	Gewicht	Zähne Stk.	Druck	Ölleistung	Schließkraft je Schale	Abmessungen				
	dm <sup>3</sup>	kg	n°	bar	l/min	Kg	A	B	C	D	E
RV550 5P	550	1300	5	300	160	2635	2000	1385	2215	1810	1545
RV550 6P	550	1350	6	300	180	2635	2000	1385	2215	1810	1545
RVG550 5P	550	1450	5	300	160	2635	2000	1385	2215	1920	1655
RVG550 6P	550	1580	6	300	180	2635	2000	1385	2215	1920	1655

 Benna a polipo per movimentazione rottame e materiali vari  
 Polyp-grab for scrap's and different materials' handling  
 Grappin pour la manipulation de la ferraille et de matériaux divers

 Mehrschalengreifer für Schrott-und verschiedenen Materialumschlag  
 Pulpos para chatarra y materiales diversos  
 Полип – грейфер для погрузки металлолома и различных материалов

> RV600A 5P





> RV600A 6P



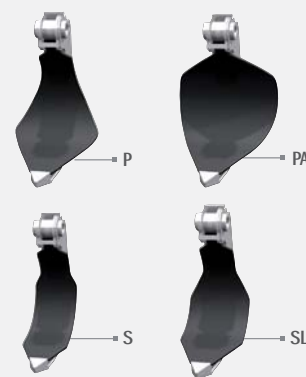
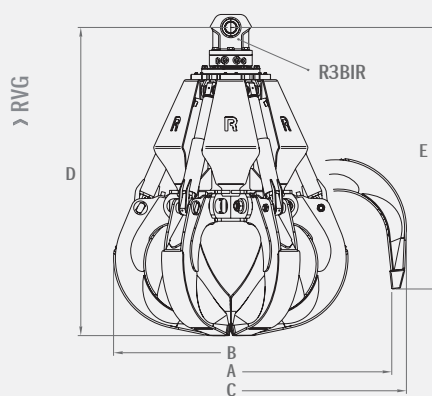
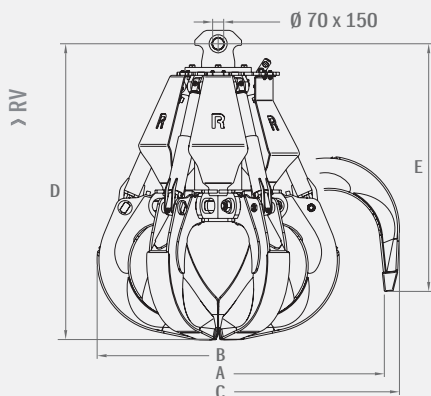

> RVG600A 6P



Modello	Capacità	Peso	Denti n°	Pressione	Portata olio	Forza al dente	Dimensioni				
Model	Capacity	Weight	Teeth no.	Pressure	Oil flow	Tooth force	Sizes				
Modèle	Capacité	Poids	Dents n.	Pression	Débit d'huile	Puissance à la dent	Dimensions				
Modell	Inhalt	Gewicht	Zähne Stk.	Druck	Ölleistung	Schließkraft je Schale	Abmessungen				
	dm <sup>3</sup>	kg	n°	bar	l/min	Kg	A	B	C	D	E
RV600A 5P	600	1500	5	300	180	2900	2110	1510	2290	1870	1580
RV600A 6P	600	1630	6	300	200	2900	2110	1510	2290	1870	1580
RVG600A 5P	600	1650	5	300	180	2900	2110	1510	2290	1980	1680
RVG600A 6P	600	1780	6	300	200	2900	2110	1510	2290	1980	1680

 Benna a polipo per movimentazione rottame e materiali vari  
 Polyp-grab for scrap's and different materials' handling  
 Grappin pour la manipulation de la ferraille et de matériaux divers

 Mehrschalengreifer für Schrott-und verschiedenen Materialumschlag  
 Pulpos para chatarra y materiales diversos  
 Полип – грейфер для погрузки металлолома и различных материалов

> RV800A 5P



> RV800A 6P



> RVG800A 5P



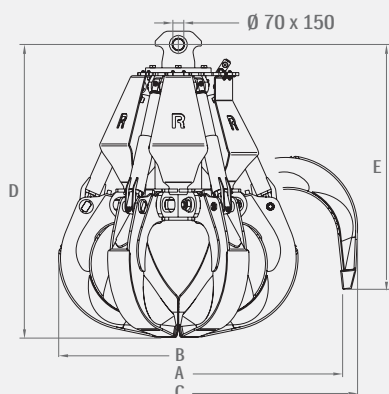

> RV



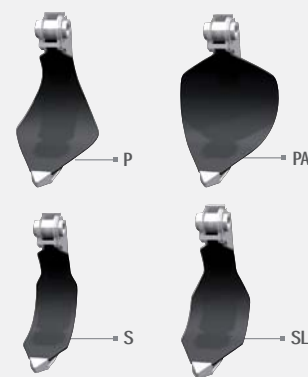
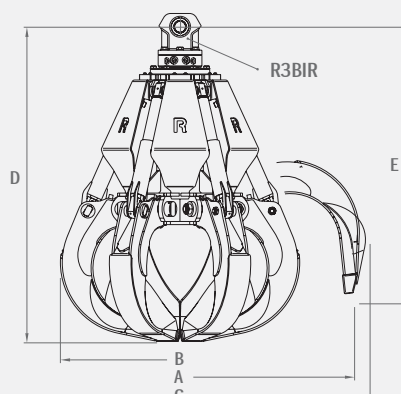

> RVG



Modello	Capacità	Peso	Denti n°	Pressione	Portata olio	Forza al dente	Dimensioni				
Model	Capacity	Weight	Teeth no.	Pressure	Oil flow	Tooth force	Sizes				
Modèle	Capacité	Poids	Dents n.	Pression	Débit d'huile	Puissance à la dent	Dimensions				
Modell	Inhalt	Gewicht	Zähne Stk.	Druck	Ölleistung	Schließkraft je Schale	Abmessungen				
	dm <sup>3</sup>	kg	n°	bar	l/min	Kg	A	B	C	D	E
RV800A 5P	800	1630	5	300	180	2600	2320	1620	2530	1980	1600
RV800A 6P	800	1700	6	300	200	2600	2320	1620	2530	1980	1600
RVG800A 5P	800	1780	5	300	180	2600	2320	1620	2530	2090	1710
RVG800A 6P	800	1900	6	300	200	2600	2320	1620	2530	2090	1710

 Benna a polipo per movimentazione rottame e materiali vari  
 Polyp-grab for scrap's and different materials' handling  
 Grappin pour la manipulation de la ferraille et de matériaux divers

 Mehrschalengreifer für Schrott-und verschiedenen Materialumschlag  
 Pulpos para chatarra y materiales diversos  
 Полип – грейфер для погрузки металлолома и различных материалов

> RV1250C 5P  
 > RV2000C 5P



> RV1000C 5P  
 > RV1500C 5P



> RV1500C 6P







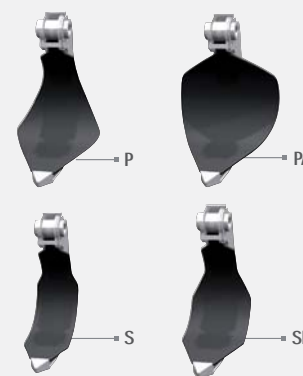
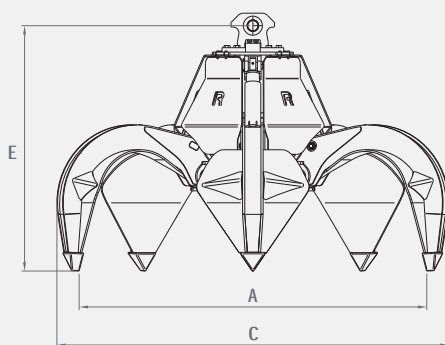
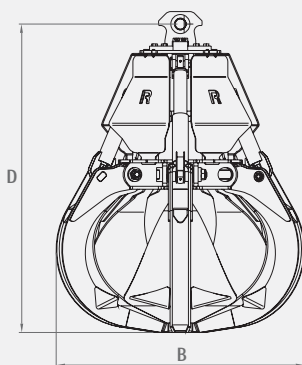

> RV1250C 6P  
 > RV2000C 6P

> RV1500C 5P



Modello	Capacità	Peso	Denti n°	Pressione	Portata olio	Forza al dente	Dimensioni				
Model	Capacity	Weight	Teeth no.	Pressure	Oil flow	Tooth force	Sizes				
Modèle	Capacité	Poids	Dents n.	Pression	Débit d'huile	Puissance à la dent	Dimensions				
Modell	Inhalt	Gewicht	Zähne Stk.	Druck	Ölleistung	Schließkraft je Schale	Abmessungen				
	dm <sup>3</sup>	kg	n°	bar	l/min	Kg	A	B	C	D	E
RV1000 5P	1000	2450	5	300	250	4570	2400	1840	2640	2265	1860
RV1250C 5P	1250	2600	5	300	250	4350	2520	1970	2760	2270	1910
RV1250C 6P	1250	2900	6	300	300	4350	2520	1970	2760	2270	1910
RV1500C 5P	1500	2850	5	300	250	3950	2760	2040	3040	2400	1960
RV1500C 6P	1500	3000	6	300	300	3950	2760	2040	3040	2400	1960
RV2000C 5P	2000	3000	5	300	250	3620	3030	2180	3330	2530	1990
RV2000C 6P	2000	3200	6	300	300	3620	3030	2180	3330	2530	1990

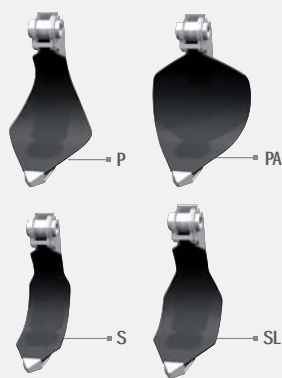
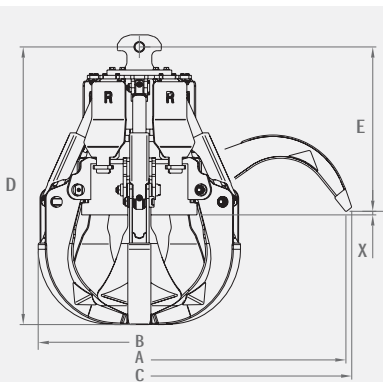
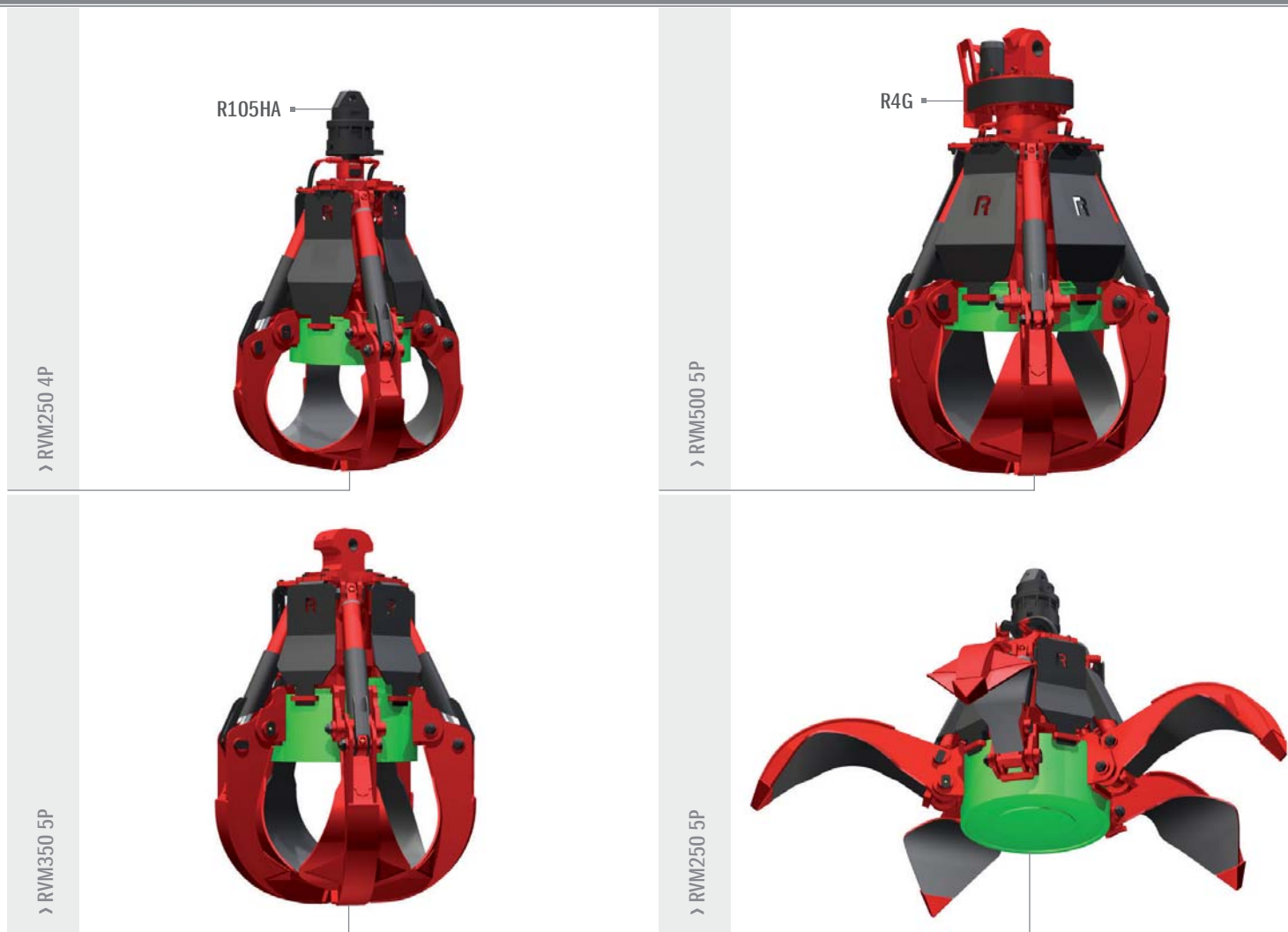

 Benna a polipo per movimentazione rottame e materiali vari  
 Polyp-grab for scrap's and different materials' handling  
 Grappin pour la manipulation de la ferraille et de matériaux divers

 Mehrschalengreifer für Schrott-und verschiedenen Materialumschlag  
 Pulpos para chatarra y materiales diversos  
 Полип – грейфер для погрузки металлолома и различных материалов



Modello	Diametro magnete	Potenza	Tensione
Model	Magnet diameter	Power	Voltage
Modèle	Diamètre de l'aimant	Puissance	Tension
Modell	Magnetdurchmesser	Leistung	Spannung
	mm	W	V DC
RVM250	550	600	24
RVM350	650	600/2000	24/220
RVM500	800	3650	220

Modello	Capacità	Peso	Denti n°	Pressione	Portata olio	Forza al dente	Dimensioni					
Model	Capacity	Weight	Teeth no.	Pressure	Oil flow	Tooth force	Sizes					
Modèle	Capacité	Poids	Dents n.	Pression	Débit d'huile	Puissance à la dent	Dimensions					
Modell	Inhalt	Gewicht	Zähne Stk.	Druck	Ölleistung	Schließkraft je Schale	Abmessungen					
	dm³	kg	n°	bar	l/min	Kg	A	B	C	D	E	X
RVM250 4P	250	650	4	300	70	1655	1575	1065	1745	1400	1285	35
RVM250 5P	250	700	5	300	90	1655	1575	1065	1745	1400	1285	35
RVM350 4P	350	940	4	300	80	1395	1900	1155	2115	1565	1410	20
RVM350 5P	350	1000	5	300	100	1395	1900	1155	2115	1565	1410	20
RVM500 4P	500	1350	4	300	130	1985	2770	1335	2835	1740	995	50
RVM500 5P	500	1530	5	300	160	1985	2770	1335	2835	1740	995	50

 Benna a polipo per movimentazione rifiuti urbani e materiali leggeri  
 Polyp-grab for waste's and light materials' handling  
 Grappin pour la manipulation des déchets et de matériaux légers

 Mehrschalengreifer für Müll-und leichten Materialumschlag  
 Pulpos para mover basura y materiales ligeros  
 Полип – грейфер для погрузки отходов и легких материалов

> RR360  
 > RR560  
 > RR650A  
 > RR700



> RR650A  
 > RR700  
 > RR800  
 > RR1100

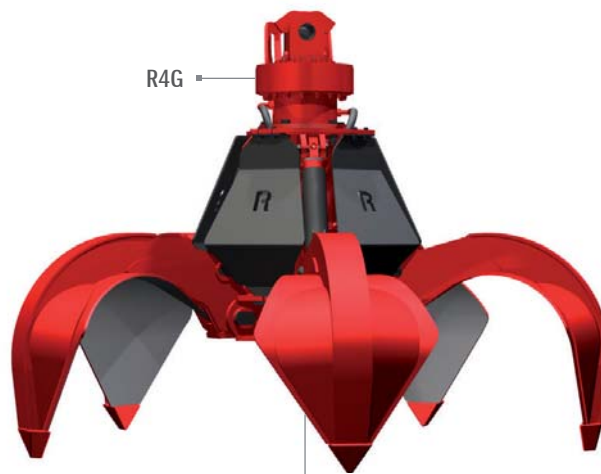

> RR360  
 > RR650A  
 > RR700

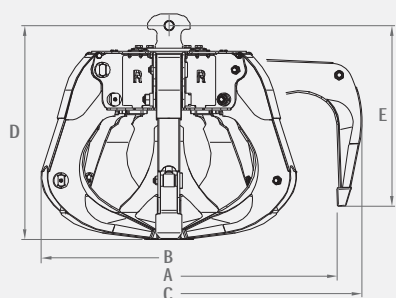



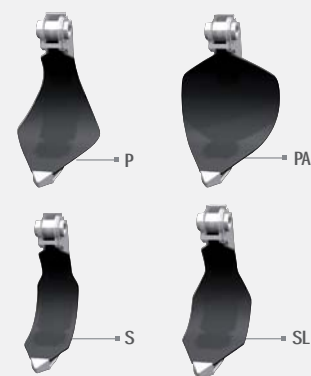
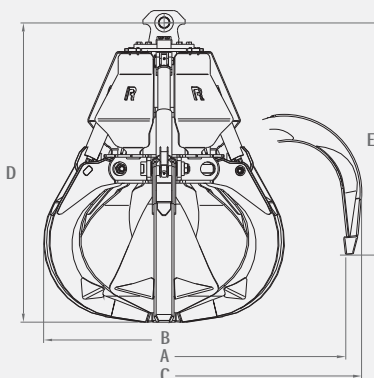



> RR560  
 > RR800  
 > RR1100



Modello	Capacità	Peso	Denti n°	Pressione	Portata olio	Forza al dente	Dimensioni				
Model	Capacity	Weight	Teeth no.	Pressure	Oil flow	Tooth force	Sizes				
Modèle	Capacité	Poids	Dents n.	Pression	Débit d'huile	Puissance à la dent	Dimensions				
Modell	Inhalt	Gewicht	Zähne Stk.	Druck	Ölleistung	Schließkraft je Schale	Abmessungen				
	dm <sup>3</sup>	kg	n°	bar	l/min	Kg	A	B	C	D	E
RR360	360	410	5	280	70	880	1800	1145	2010	1080	820
RR560	560	660	5	300	90	1270	2000	1310	2110	1460	1110
RR650A	650	920	5	320	120	2300	2000	1490	2215	1250	1020
RR700	700	1060	5	320	160	2600	2150	1520	2410	1350	1060
RR800	800	1250	5	300	150	2360	2200	1600	2430	1935	1515
RR1100	1100	1650	5	300	180	2370	2550	1680	2770	2100	1620



 Benna a polipo per movimentazione massi  
 Polyp-grab for blocks handling  
 Grappin pour la manipulation des blocs

 Greifer für Gesteinsblöcke  
 Pulpos para rocas  
 Полип-грефер для погрузки строительных блоков

> RM400



> RM901



> RM601



> RM901

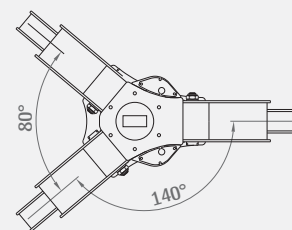
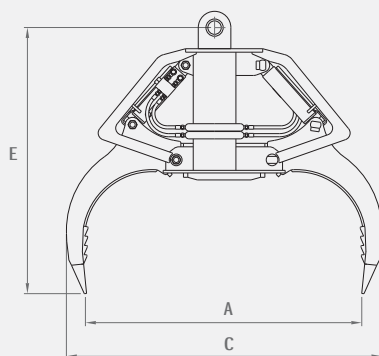
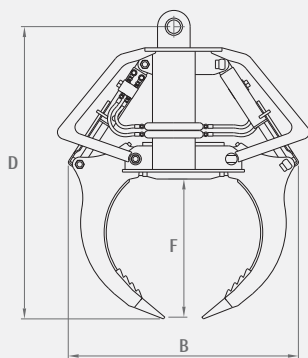

Modello	Portata	Peso	Denti n°	Pressione	Portata olio	Forza al dente	Dimensioni					
Model	Lifting power	Weight	Teeth no.	Pressure	Oil flow	Tooth force	Sizes					
Modèle	Portée	Poids	Dents n.	Pression	Débit d'huile	Puissance à la dent	Dimensions					
Modell	Tragkraft	Gewicht	Zähne Stk.	Druck	Ölleistung	Schließkraft je Schale	Abmessungen					
	kg	kg	n°	bar	l/min	Kg	A	B	C	D	E	F
<b>RM400</b>	3500	650	3	280	90	3750	1600	1300	1810	1680	1540	810
<b>RM601</b>	5000	950	3	280	120	4820	1850	1650	2150	1900	1800	990
<b>RM901</b>	8000	1700	3	280	250	9140	2450	2300	2700	2470	2250	1260





## DEMOLITORI SELEZIONATORI

I demolitori selezionatori idraulici RS sono progettati e realizzati per eseguire la demolizione di strutture in laterizio e permettere la selezione dei vari materiali di risulta; sono inoltre utilizzabili per la movimentazione di macerie, rifiuti, legno, pietre. Date le loro caratteristiche, possono essere impiegati per accelerare le operazioni di soccorso in caso di catastrofi naturali. Sono costituiti da due valve con movimento sincronizzato fulcrate ad una solida incastellatura. Le attrezzature sono equipaggiate con robusto rotatore idraulico collegato rigidamente al braccio escavatore per assicurare la massima precisione di lavoro. I cilindri sono dotati di una valvola di sicurezza che impedisce l'apertura involontaria in caso di improvvisi cali di pressione. Controlame intercambiabili sono fornite a richiesta. Un'attenta progettazione ed innovativi processi di lavorazione assicurano affidabilità e massime prestazioni anche in condizioni di lavoro gravose. La carpenteria ed i cilindri sono realizzati con materiali di elevata qualità e resistenza mentre la parti soggette ad abrasione sono costruite in acciaio antiusura HB400. I perni e le boccole sono realizzati in acciai speciali con trattamento termico di indurimento, in modo da garantire una lunga durata anche con scarsa lubrificazione.

## DEMOLITION AND SORTING GRABS

The demolition and sorting grabs RS are designed and manufactured to perform the demolition of brick buildings and allow the selection of different materials resulting from this work; they are also used for the handling of rubble, waste, wood and stones. Given their characteristics, they can be used to speed up the rescue operations in case of natural disasters. They consist of two halves with synchronized movement which are pivoted to a strong frame-work. The equipment is equipped with a strong hydraulic rotator, rigidly connected to the excavator arm to ensure maximum precision work. The cylinders are equipped with a safety valve that prevents accidental opening in the event of sudden pressure drops. Interchangeable bolted edge are provided on request. Careful design and innovative manufacturing processes ensure reliability and maximum performance even in harsh working conditions. The steelwork and cylinders are made of high quality and durable materials while the parts subject to abrasion are made of wear-resistant steel HB400. The pins and the bushings are made of special steel with heat treatment for hardening, so as to ensure a long life even with poor lubrication.

## PINCES Á TRIER ET Á DÉMOLIR

Les pinces hydrauliques à trier et à démolir sont conçues et fabriquées pour exécuter la démolition de structures en briques et pour permettre la sélection de matériaux différents qui en résultent; elles sont également utilisées pour le traitement des gravats, déchets, bois et pierres. Compte tenu de leurs caractéristiques, elles peuvent être utilisées pour accélérer les opérations de secours en cas de catastrophes naturelles. Elles sont constituées de deux coquilles, ayant un mouvement synchronisé, et fixées à un bâti solide. Les équipements sont équipés avec un rotator hydraulique robuste connecté d'une façon rigide au bras de la pelle pour assurer un travail de précision maximale. Les vérins sont équipés d'un clapet de sécurité qui empêche l'ouverture accidentelle en cas de chute de pression soudaine. Des contre-lames interchangeables sont disponibles sur demande. Une conception soignée et des procédés de fabrication innovants garantissent la fiabilité et des performances optimales, même dans des conditions difficiles de travail. La structure et les vérins sont réalisés avec des matériaux de haute qualité et de durabilité tandis que les pièces sujettes à l'usure sont en acier anti-usure Hardox HB400. Les axes et les bagues sont en acier spécial avec un traitement thermique de durcissement, de manière à assurer une longue durée de vie, même avec une mauvaise lubrification.

## ABRUCH- UND SORTIERGREIFER



Die Abbruch-und Sortiergreifer der Serie RS wurden eigens für den Abbruch von Ziegelsteinen entwickelt und ermöglichen das Sortieren der wieder verwertbaren Restmaterialien. Aufgrund der technischen Eigenschaften sind diese Greifer auch bei Naturkatastrophen eine effektive und schnelle Hilfe. Sie bestehen aus zwei sich synchron bewegenden Schalen, die an einem stabilen Grundgestell befestigt sind. Die Sortiergreifer haben leistungsstarke Drehmotoren, die eine präzise Arbeit verrichten. Die Zylinder sind mit einem Sicherheitsventil ausgestattet, um ein ungewolltes Öffnen der Schalen bei plötzlichem Druckabfall zu verhindern. Verschraubbare Schneidmesser sind als Zubehör lieferbar. Eine gewissenhafte Projektierung und ein innovativer Arbeitsablauf gewährleisten eine hohe Zuverlässigkeit und optimale Arbeitsleistungen auch unter schwierigsten Einsatzbedingungen. Die Stahlkonstruktion und die Zylinder werden aus hochwertigem Material gefertigt und die Teile, die einem besonders starken Abrieb ausgesetzt sind, aus verschleißfestem Stahl HB 400. Die Bolzen und Buchsen sind aus Spezialstahl mit thermischer Härtebehandlung, um auch unter schwierigen Bedingungen und trotz unzureichender Schmierung eine lange Lebensdauer zu gewährleisten.



## DEMOLEDORES SELECCIONADORES

Los demoldores seleccionadores hidráulicos RS están diseñados para derruir contrucciones de ladrillos y garantizar la selección de materiales; también pueden ser utilizados para mover detritos, basuras, madera y piedras. Por sus características, se pueden usar para las operaciones de ayuda en caso de catástrofe natural. Están dotados de dos valvas con movimiento simultáneo con el núcleo notablemente reforzado. Dichos equipos están dotados de un extraordinario rotor hidráulico unido rigidamente al brazo escavador para garantizar la máxima precisión de trabajo. Los cilindros incorporan válvulas de seguridad con el fin de evitar la apertura involuntaria en casos de descenso de presión en el circuito hidráulico de los mismos. Su novedoso diseño unidos a inovadores procesos de fabricación, aseguran excelentes prestaciones incluso en trabajos pesados. La fabricación de los cilindros está hecha con materiales de calidad y resistencia, de tal manera que, los elementos expuestos a desgaste por abrasión están fabricados con acero para evitar su abrasión, como el HB400. Pernos y cajas del eje están hechos con aceros especiales con tratamiento térmico de endurecimiento con el fin de garantizar una larga durabilidad incluso en situaciones de sequedad y poca lubricación.



## ГРЕЙФЕРЫ ДЛЯ РАЗРУШЕНИЯ И СОРТИРОВКИ

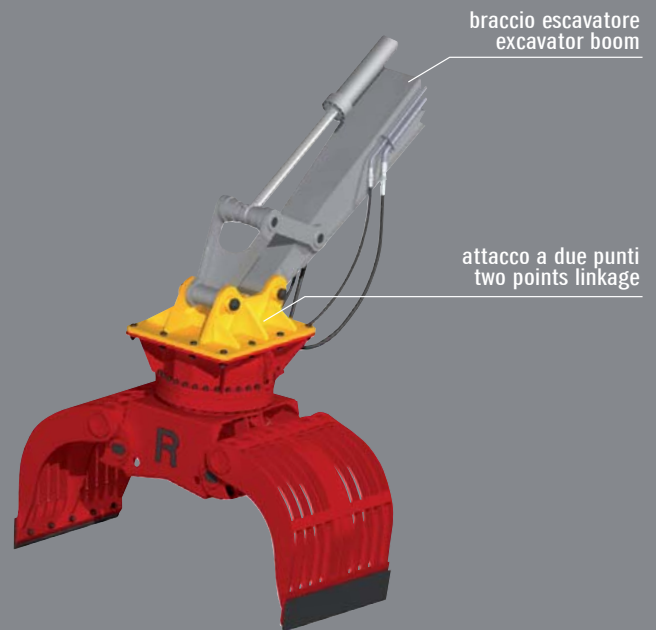
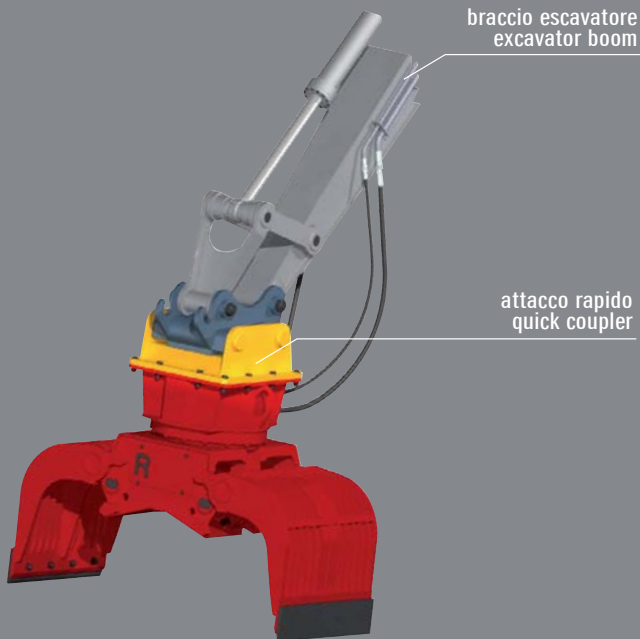

Грейферы для разрушения и сортировки серии RS спроектированы и изготовлены специально для разрушения кирпичных зданий и сортировки отходов, которые остаются после этого; также они используются для перемещения валунов, отходов, дерева и камней. Благодаря своим характеристикам, их возможно использовать для ускорения разбора завалов при различных природных бедствиях. Они состоят из двух половинок с синхронным движением, которые прикручены к жесткому каркасу. Оборудование оснащено мощным гидравлическим ротатором, жестко соединенным к рукояти экскаватора для максимально точной работы. Цилиндры оборудованы клапаном безопасности, который предотвращает случайное открытие в случае понижения давления. По желанию могут быть предоставлены заменяемые пластины. Продуманный дизайн и современный процесс изготовления гарантируют отличную работу даже в сложных условиях. Стальная конструкция и цилиндры выполнены из высококачественных износостойких материалов, в то время как части, подверженные износу, выполнены из износостойкой стали HB400. Пальцы и втулки сделаны из специальной закаленной стали, которые долго служат даже при тяжелых условиях и при недостатке смазки.

 Esempi di applicazione  
 Examples of application  
 Exemples d'application

 Anwendungsbeispiele  
 Ejemplos de aplicacion  
 Примеры комплектации



 Schema di utilizzo per demolitori e selezionatori  
 Scheme of use for demolition and sorting grabs  
 Schéma d'emploi pour pinces à trier et à démolir

 Anwendungsübersicht für Abbruch- und Sortiergreifer  
 Esquema de uso para pinzas para demolición y selección  
 Схема использования грейферов для разрушения и сортировки.

Demolitori / Selezionatori Demolition and sorting grabs	Peso escavatore / Caricatore Excavator / Loader weight
RS100 (R605 / R104X)	1,5 - 4
RS195 - RS200 (R606)	3 - 6
RSG300F	6 - 12
RSG400F - RSG450F	10 - 15
RS500	13 - 20
RS600	14 - 20
RS800	19 - 25
RS1000	22 - 32
RS1150	24 - 32
RS1300	26 - 32

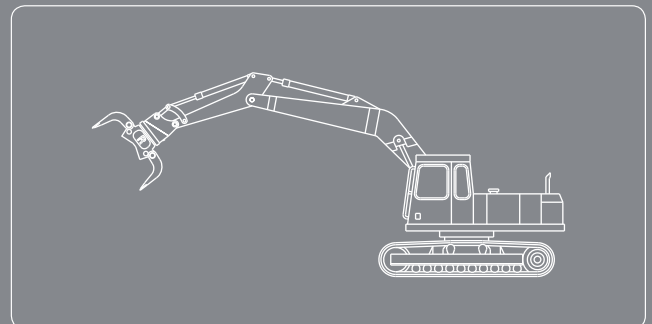

- Demolitori selezionatori
- Demolition and sorting grabs
- Pincas à trier et à démolir

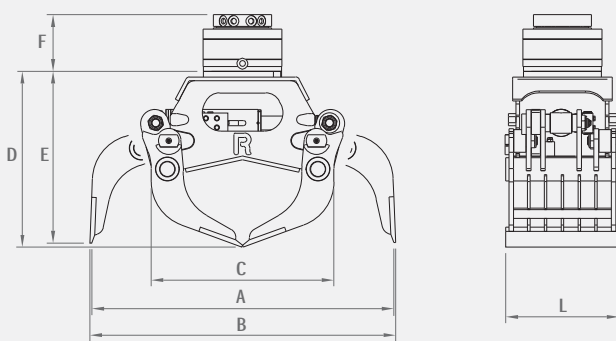
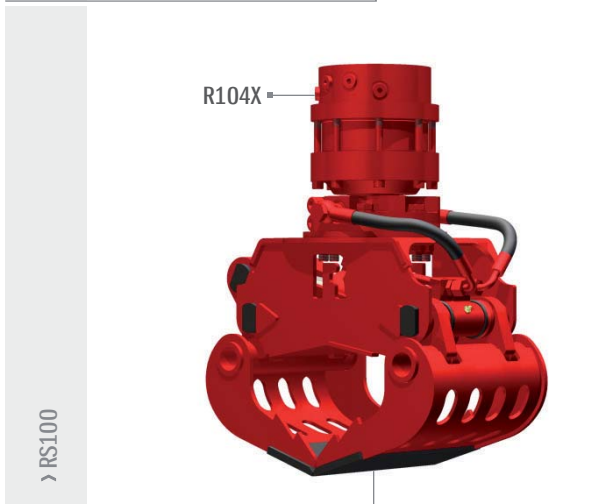
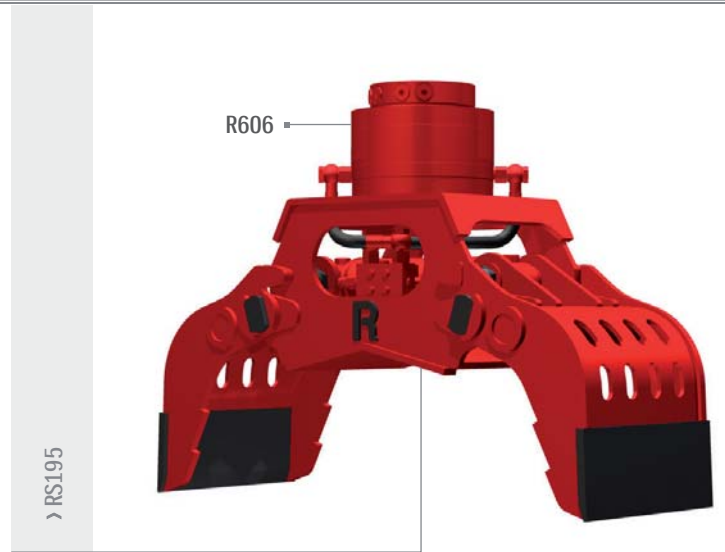

- Abbruch- und Sortiergreifer
- Pinzas para demolición y selección
- Грейферы для разрушения и сортировки



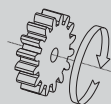

Modello	Peso	Dimensioni
Model	Weight	Sizes
Modèle	Poids	Dimensions
Modell	Gewicht	Abmessungen
	kg	F
<b>R104X</b>	45	270
<b>R605</b>	40	180
<b>R606</b>	55	185

Modello	Capacità	Peso	Pressione	Portata olio	Pressione	Portata olio	Forza alla lama	Dimensioni
Model	Capacity	Weight	Pressure	Oil flow	Pressure	Oil flow	Tine force	Sizes
Modèle	Capacité	Poids	Pression de travail	Débit d'huile	Pression de travail	Débit d'huile	Puissance à la lame	Dimensions
Modell	Inhalt	Gewicht	Druck	Ölleistung	Druck	Ölleistung	Schließkraft je Schale	Abmessungen
	dm <sup>3</sup>	kg	bar	l/min	bar	l/min	Kg	A B C D E L
<b>RS100</b>	17	70	300	20	250	20	1150	675 700 490 380 360 300
<b>RS195</b>	40	150	300	30	250	20	2320	970 1000 670 600 580 370
<b>RS200F</b>	40	150	300	30	250	20	2320	970 1000 670 600 580 370



 Demolitori selezionatori  
 Demolition and sorting grabs  
 Pincès à trier et à démolir

 Abbruch- und Sortiergreifer  
 Pinzas para demolición y selección  
 Грейферы для разрушения и сортировки

> RSG300F



> RSG400 > RSG450

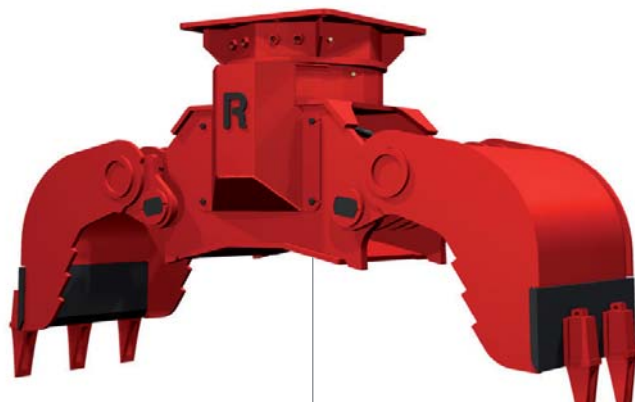

> RSG300





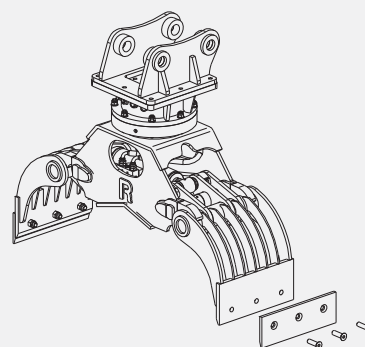
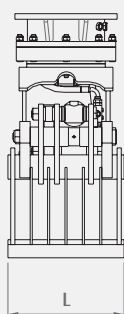
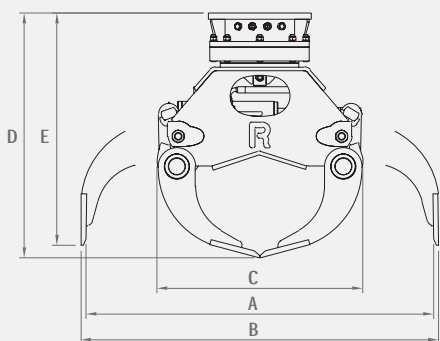

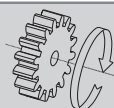

> RSG400F > RSG450F



Modello	Capacità	Peso	Pressione	Portata olio	Pressione	Portata olio	Forza alla lama	Dimensioni					
Model	Capacity	Weight	Pressure	Oil flow	Pressure	Oil flow	Tine force	Sizes					
Modèle	Capacité	Poids	Pression de travail	Débit d'huile	Pression de travail	Débit d'huile	Puissance à la lame	Dimensions					
Modell	Inhalt	Gewicht	Druck	Ölleistung	Druck	Ölleistung	Schließkraft je Schale	Abmessungen					
	dm <sup>3</sup>	kg	bar	l/min	bar	l/min	Kg	A	B	C	D	E	L
RSG300F	100	390	300	50	250	30	2500	1350	1400	800	950	900	450
RSG400F	220	750	300	60	150	30	3300	1800	1840	1110	1180	960	600
RSG450F	260	780	300	60	150	30	3300	1800	1840	1110	1180	960	700



-  Demolitori selezionatori
-  Demolition and sorting grabs
-  Pincas à trier et à démolir

-  Abbruch- und Sortiergreifer
-  Pinzas para demolición y selección
-  Грейферы для разрушения и сортировки

> RS500 > RS600

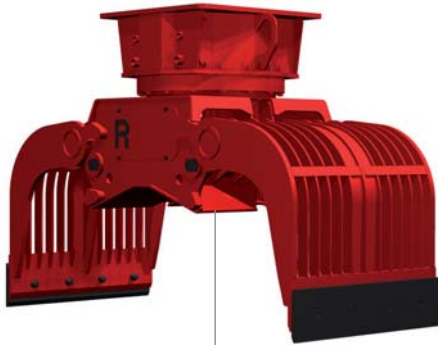

> RS800



> RS500 > RS600



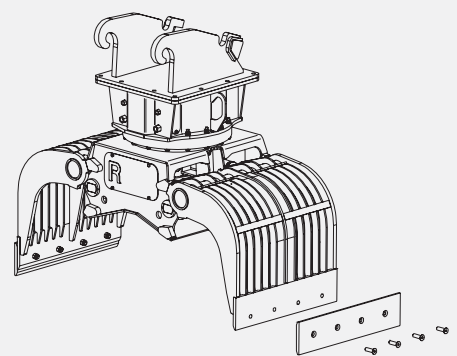
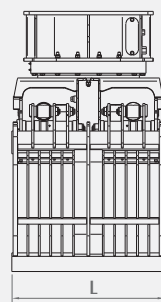
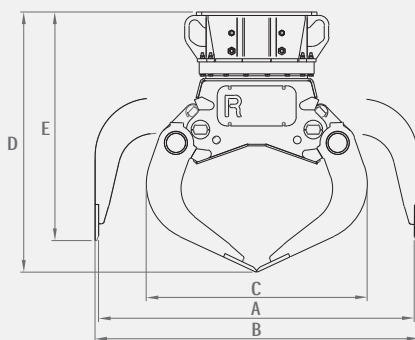

> RS800



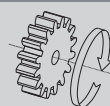

Modello	Capacità	Peso	Pressione	Portata olio	Pressione	Portata olio	Forza alla lama	Dimensioni					
Model	Capacity	Weight	Pressure	Oil flow	Pressure	Oil flow	Tine force	Sizes					
Modèle	Capacité	Poids	Pression de travail	Débit d'huile	Pression de travail	Débit d'huile	Puissance à la lame	Dimensions					
Modell	Inhalt	Gewicht	Druck	Ölleistung	Druck	Ölleistung	Schließkraft je Schale	Abmessungen					
	dm <sup>3</sup>	kg	bar	l/min	bar	l/min	Kg	A	B	C	D	E	L
RS500	500	990	320	80	170	30	4100	1760	1800	1230	1400	1230	850
RS600	600	1050	320	80	170	30	4100	1760	1800	1230	1400	1230	1000
RS800	800	1500	320	120	170	30	5600	2000	2060	1360	1620	1440	1000





 Demolitori selezionatori  
 Demolition and sorting grabs  
 Pincès à trier et à démolir

 Abbruch- und Sortiergreifer  
 Pinzas para demolición y selección  
 Грейферы для разрушения и сортировки

RS1000 > RS1150 > RS1300

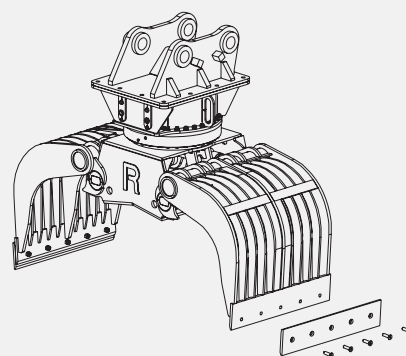
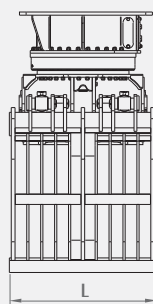
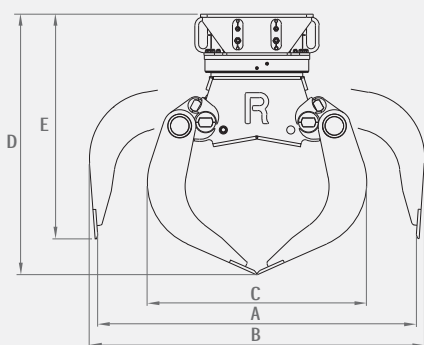

Modello	Capacità	Peso	Pressione	Portata olio	Pressione	Portata olio	Forza alla lama	Dimensioni					
Model	Capacity	Weight	Pressure	Oil flow	Pressure	Oil flow	Tine force	Sizes					
Modèle	Capacité	Poids	Pression de travail	Débit d'huile	Pression de travail	Débit d'huile	Puissance à la lame	Dimensions					
Modell	Inhalt	Gewicht	Druck	Ölleistung	Druck	Ölleistung	Schließkraft je Schale	Abmessungen					
	dm <sup>3</sup>	kg	bar	l/min	bar	l/min	Kg	A	B	C	D	E	L
RS1000	1000	1690	320	120	170	30	5050	2200	2280	1490	1740	1490	1000
RS1150	1150	1770	320	120	170	30	5050	2200	2280	1490	1740	1490	1150
RS1300	1300	1850	320	120	170	30	5050	2200	2280	1490	1740	1490	1300

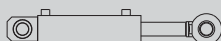





 PINZE

Le pinze sono attrezzature idrauliche idonee al carico di tronchi, rami, travi, traverse per ferrovia, tubi e tondi. Sono costituite da due valve, con forma ottimizzata per garantire il massimo carico, fulcrate ad una robusta incastellatura e sincronizzate da bielle di bilanciamento. Solitamente sono equipaggiate con rotatore idraulico. I cilindri sono dotati di una valvola di blocco di sicurezza che impedisce l'apertura involontaria della pinza in caso di improvvisi cali di pressione. L'utilizzo di acciai speciali e materiali di elevata qualità uniti a tecniche di produzione all'avanguardia assicurano notevoli prestazioni e durata nel tempo anche in condizioni gravose.

 TIMBER GRABS

The timber grabs are hydraulic equipment suitable for the loading of logs, branches, beams, railway sleepers, pipes and round products. They consist of two tines designed with the optimal shape for maximum load, they are pivoted on a robust frame-work with synchronized movement. Hydraulic rotators are available for all models. The cylinders are equipped with a safety valve that prevents inadvertent opening of the grab in the event of sudden pressure drops. The use of special steels and high-quality materials combined with modern manufacturing techniques ensure high performance and long life even in harsh conditions.

 PINCES

Les pinces sont des équipements hydrauliques adaptées à la charge des troncs, branches, poutres, traverses de chemin de fer, tuyaux et ronds. Elles se composent de deux coquilles conçues avec une forme optimisée pour une charge maximale, elles sont articulées à un bâti robuste et avec un mouvement synchronisé. Des rotators hydrauliques sont disponibles pour tous les modèles. Les vérins sont équipés d'une soupape de sécurité qui empêche l'ouverture accidentelle de la pince dans le cas d'une chute de pression soudaine. L'utilisation d'aciers spéciaux et de matériaux de haute qualité combinés avec des techniques de fabrication modernes garantissent de hautes performances et une longue durée de vie même dans des conditions difficiles.

 ZANGEN



Die Zangen sind hydraulische Ausrüstungen für den Umschlag von Baumstämmen, Ästen, Balken, Trägern, Bahnschwellen, Rohren und Runden. Sie bestehen aus 2 sich synchron bewegenden Schalen, projektiert für einen optimalen Materialumschlag, sowie aus einem stabilen Grundgestell. Für alle Modelle sind Drehmotoren verfügbar. Die Zylinder sind mit einem Sicherheitsventil ausgestattet, um ein ungewolltes Öffnen der Schalen bei plötzlichem Druckabfall zu verhindern. Der Einsatz von Spezialstahltypen und anderen hochwertigen Materialien, verbunden mit innovativer Produktionstechnik gewährleisten eine hohe Arbeitsleistung und eine lange Lebensdauer auch beim Einsatz unter schwierigsten Bedingungen.



 PINZAS

Pinzas son equipos hidráulicos utilizados para mover troncos, ramas, travesaños de ferrocarril y tuberías. Dichos equipos constan de dos valvas con movimientos simultáneos con el núcleo protegido. Se suministran con rotores hidráulicos para todos los modelos de la gama. Los cilindros vienen equipados con válvulas de seguridad para evitar la apertura involuntaria en caso de pérdidas de presión. El uso de aceros especiales y procesos de fabricación de última generación garantizan máximas prestaciones y longevidad de nuestros equipos incluso en situaciones de trabajos pesados.



 ЛЕСНЫЕ ГРЕЙФЕРЫ

Лесные грейферы – это гидравлическое оборудование, которое подходит для погрузки бревен, веток, балок, железнодорожных вагонов, труб и круглых материалов. Они состоят из двух лепестков с оптимальной формой для погрузки, они прикручены к жесткому каркасу для синхронного движения. Гидравлические ротаторы доступны для всех моделей. Цилиндры оборудованы клапаном безопасности, который предотвращает случайное открытие в случае понижения давления. Использование специальной стали и высококачественных материалов при современном производстве гарантируют долгую службу даже в сложных условиях.

 Esempi di applicazione  
 Examples of application  
 Exemples d'application

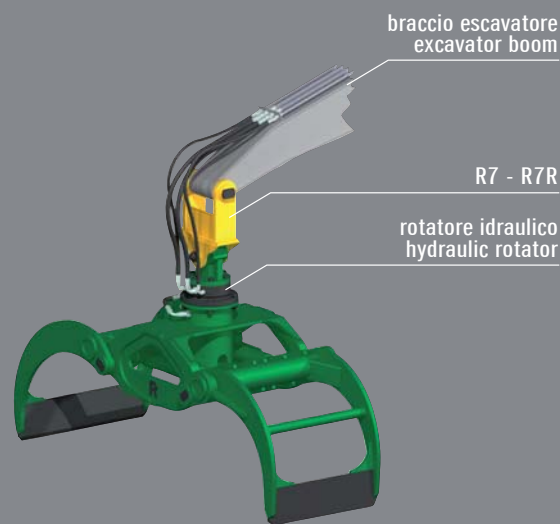
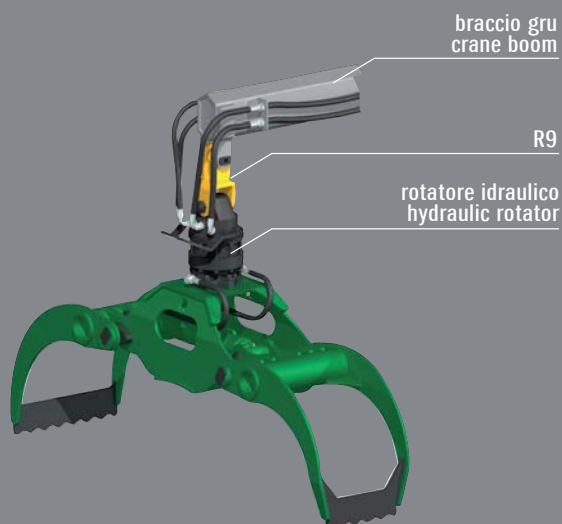
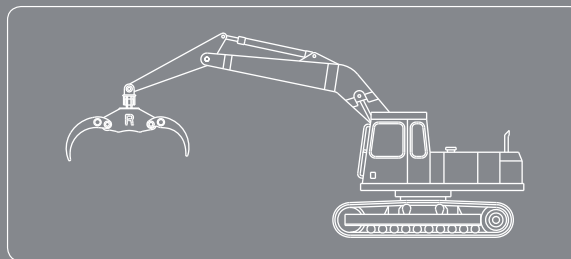
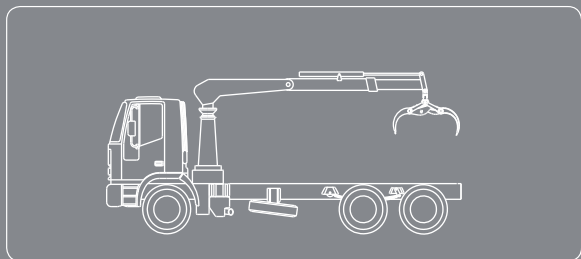

 Anwendungsbeispiele  
 Ejemplos de aplicacion  
 Примеры комплектации





 Schemi utilizzo per pinze  
 Scheme of use for timber grabs  
 Schéma d'emploi pour pinces

 Anwendungsübersicht für Zangen  
 Esquema de uso para pinzas  
 Схема использования лесных грейферов



Pinze Timber grabs	Gancio Hook	Rotatore idraulico Hydraulic rotator	Peso escavatore / caricatore Excavator / loader weight
R50/225 - 250	R9	R102 - R103 - R104	2.5 - 5
R50/350 - 375 - 500	R9	R104 - R05 - R105	5 - 9
R50/427	R7 - R9	R05 - R105 - R105H - R1G	6 - 12
R50/401	R7	R3IR - R1G	11 - 17
R53 LE	R7 - R7R	R3IR - R1G - R4G	13 - 18
R53	R7 - R7R	R3IR - R3BIR - R4G	16 - 23
R50/604	R7R	R3BIR - R4G	18 - 25
R50/803	R7R	R3BIR - R4G	23 - 30
R44/802	R7R	R3BIR - R3C - R4G	24 - 32
R44/900	R7R	R3BIR - R3C	26 - 35
R44/1000	R7R	R3BIR - R3C	27 - 37
R55.1	R7 - R7R	R3IR - R3BIR - R1G - R4G	13 - 20
R55.2	R7 - R7R	R3IR - R3BIR - R1G - R4G	14 - 21
R56	R7R	R3BIR - R3C	23 - 35

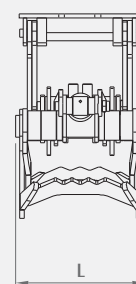
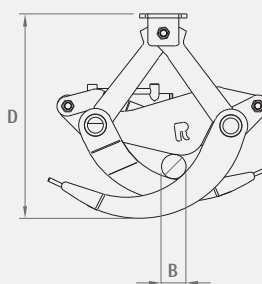
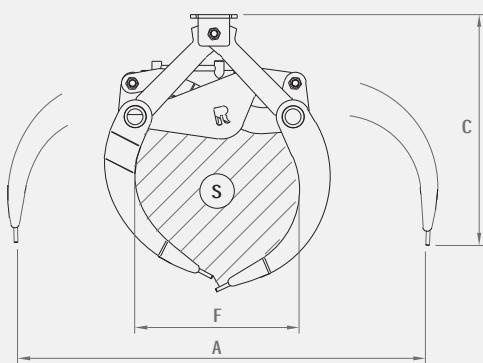

-  Pinze per movimentazione tronchi e materiali vari
-  Grabs for logs' and different materials' handling
-  Pincés pour la manipulation de troncs et de matériaux divers

-  Holzgreifer und verschiedenen Materialumschlag
-  Pinzas para troncos y materiales diversos
-  Грейфер для круглого леса и других материалов





Modello	Area	Portata	Peso	Pressione	Portata olio	Dimensioni					
Model	Surface	Lifting capacity	Weight	Pressure	Oil flow	Sizes					
Modèle	Surface	Portée	Poids	Pression	Débit d'huile	Dimensions					
Modell	Oberfläche	Tragkraft	Gewicht	Druck	Ölleistung	Abmessungen					
	S - m <sup>2</sup>	Kg	kg	bar	l/min	A	B	C	D	L	F
R50/250	0,2	800	120	180	30	1310	60	790	680	390	530
R50/350	0,3	1200	195	180	50	1450	80	880	760	500	650
R50/500	0,5	1500	220	180	50	1750	250	950	940	510	880

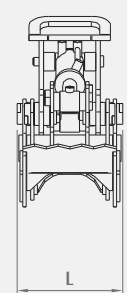
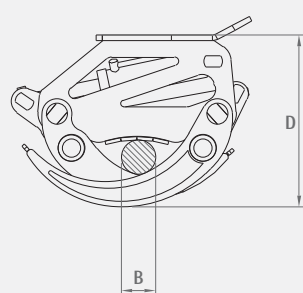
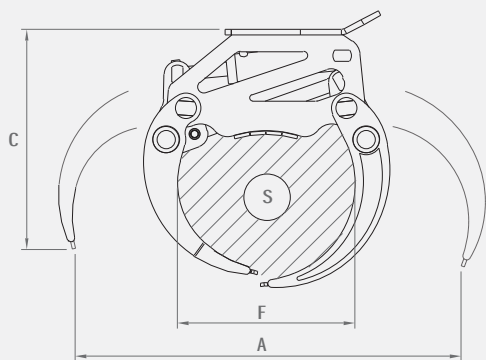

 Pinze per movimentazione tronchi e materiali vari  
 Grabs for logs' and different materials' handling  
 Pincés pour la manipulation de troncs et de matériaux divers

 Holzgreifer und verschiedenen Materialumschlag  
 Pinzas para troncos y materiales diversos  
 Грейфер для круглого леса и других материалов



Modello	Area	Portata	Peso	Pressione	Portata olio	Dimensioni					
Model	Surface	Lifting capacity	Weight	Pressure	Oil flow	Sizes					
Modèle	Surface	Portée	Poids	Pression	Débit d'huile	Dimensions					
Modell	Oberfläche	Tragkraft	Gewicht	Druck	Ölleistung	Abmessungen					
	S - m <sup>2</sup>	Kg	kg	bar	l/min	A	B	C	D	L	F
R50/225	0,2	800	115	220	30	1170	60	630	460	370	470
R50/375	0,3	1400	210	250	50	1400	130	860	620	380	640
R50/427	0,4	2000	250	300	70	1910	130	790	620	530	710



 Pinze per movimentazione tronchi e materiali vari  
 Grabs for logs' and different materials' handling  
 Pincés pour la manipulation de troncs et de matériaux divers

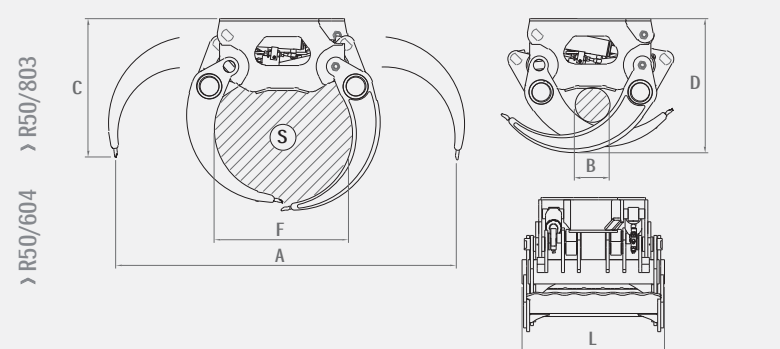
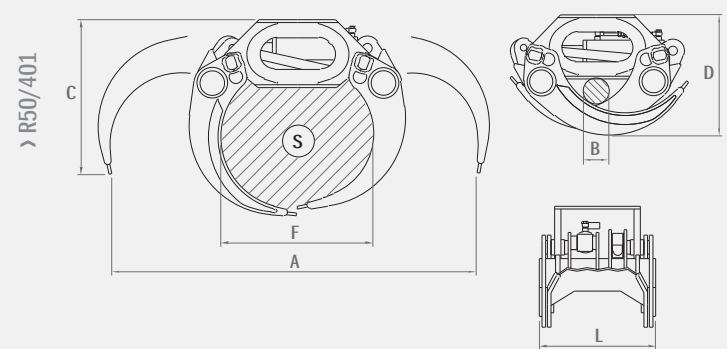

 Holzgreifer und verschiedenen Materialumschlag  
 Pinzas para troncos y materiales diversos  
 Грейфер для круглого леса и других материалов



Modello	Area	Portata	Peso	Pressione	Portata olio	Dimensioni					
Model	Surface	Lifting capacity	Weight	Pressure	Oil flow	Sizes					
Modèle	Surface	Portée	Poids	Pression	Débit d'huile	Dimensions					
Modell	Oberfläche	Tragkraft	Gewicht	Druck	Ölleistung	Abmessungen					
	S - m <sup>2</sup>	Kg	kg	bar	l/min	A	B	C	D	L	F
R50/401	0,4	3000	405	280	70	1900	140	810	670	640	800
R50/604	0,6	4000	800	280	90	2160	230	890	890	920	900
R50/803	0,8	6000	1150	300	160	2620	200	1040	940	1080	1100







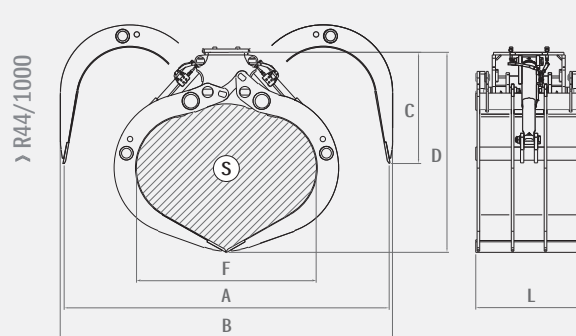
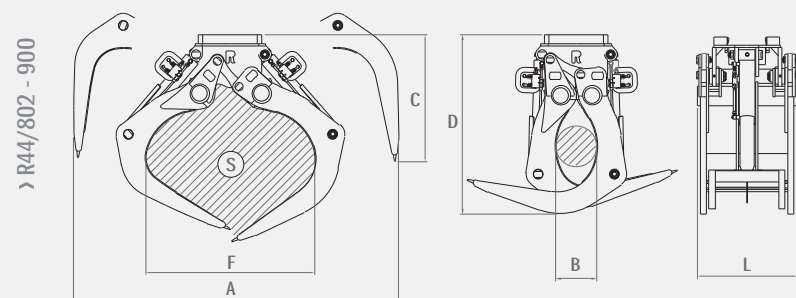
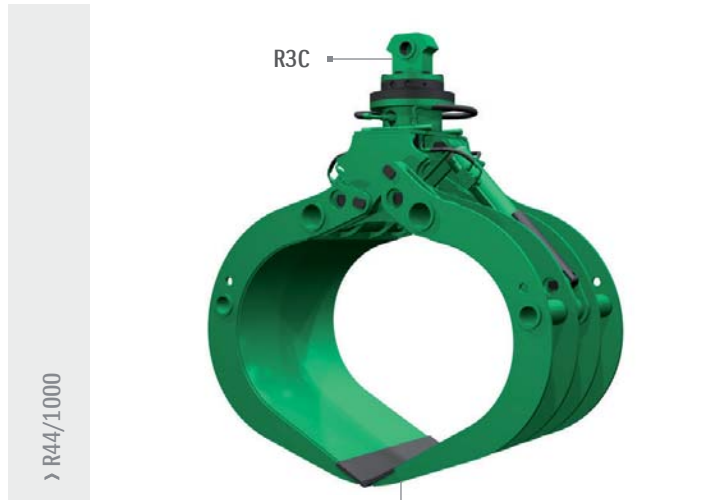
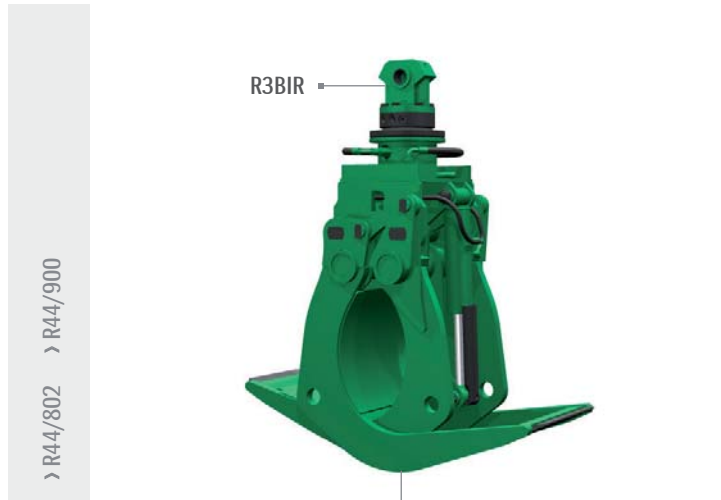
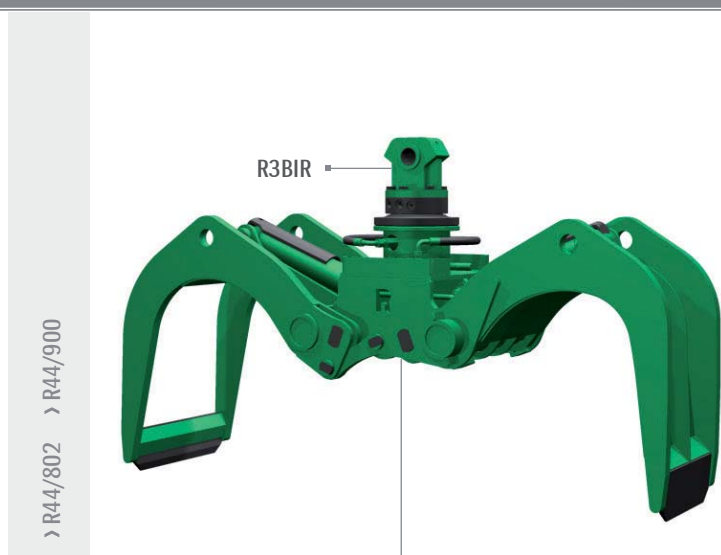

 Pinze per movimentazione tronchi e materiali vari  
 Grabs for logs' and different materials' handling  
 Pincès pour la manipulation de troncs et de matériaux divers

 Holzgreifer und verschiedenen Materialumschlag  
 Pinzas para troncos y materiales diversos  
 Грейфер для круглого леса и других материалов





Modello	Area	Portata	Peso	Pressione	Portata olio	Dimensioni					
Model	Surface	Lifting capacity	Weight	Pressure	Oil flow	Sizes					
Modèle	Surface	Portée	Poids	Pression	Débit d'huile	Dimensions					
Modell	Oberfläche	Tragkraft	Gewicht	Druck	Ölleistung	Abmessungen					
	S - m <sup>2</sup>	Kg	kg	bar	l/min	A	B	C	D	L	F
R44/802	1,1	6000	1400	280	180	2680	340	1220	1480	820	1380
R44/900	1,45	6000	1500	280	180	2900	480	1270	1620	900	1650
R44/1000	1,6	6000	1780	300	180	3040	3110	1050	1870	1000	1680

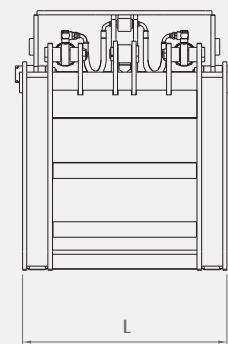
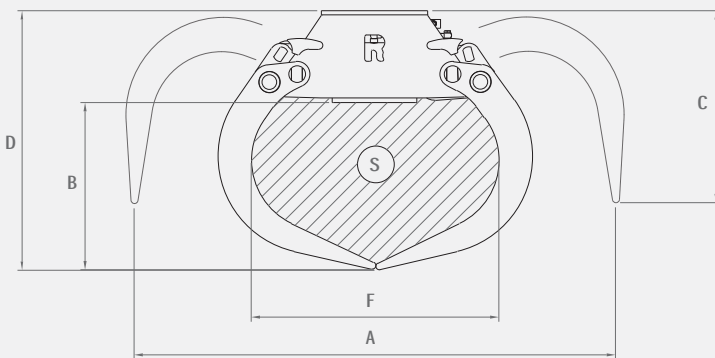
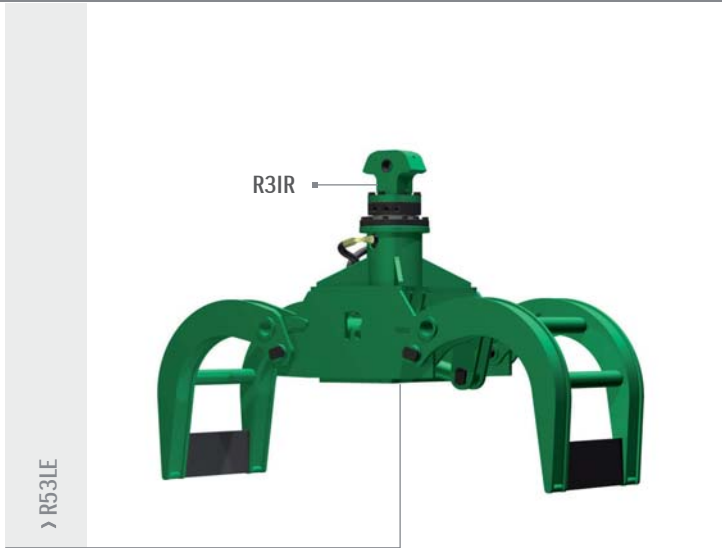

 Pinze per movimentazione di traverse ferroviarie e materiali vari  
 Grabs for railway sleepers' and different materials' handling  
 Pincés pour la manipulation de traverses de chemin de fer et de matériaux divers

 Zangen für Eisenbahnschwellen- und verschiedenen Materialumschlag  
 Pinzas para traviesas ferroviarias y materiales diversos  
 Грейферы для погрузки ж/д шпал и других материалов



Modello	Area	Portata	Peso	Pressione	Portata olio	Dimensioni					
Model	Surface	Lifting capacity	Weight	Pressure	Oil flow	Sizes					
Modèle	Surface	Portée	Poids	Pression	Débit d'huile	Dimensions					
Modell	Oberfläche	Tragkraft	Gewicht	Druck	Ölleistung	Abmessungen					
	S - m <sup>2</sup>	Kg	kg	bar	l/min	A	B	C	D	L	F
R53LE	0,6	2500	620	280	90	1960	660	850	1080	760	1070
R53	0,7	3000	730	280	90	2150	750	900	1170	950	1130

 Pinze per movimentazione di binari ferroviari e materiali vari  
 Grabs for railway tracks' and different materials' handling  
 Pincés pour la manipulation de rails et de matériaux divers

 Zangen für Gleise- und verschiedenen Materialumschlag  
 Pinzas para railes ferroviarios y materiales diversos  
 Грейферы для погрузки ж/д шпал и других материалов

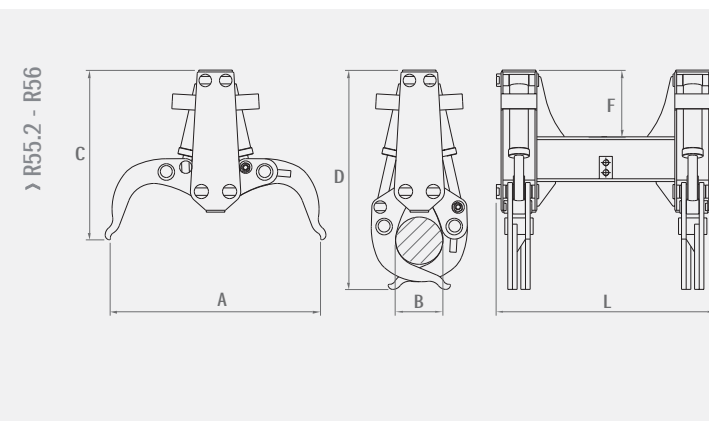
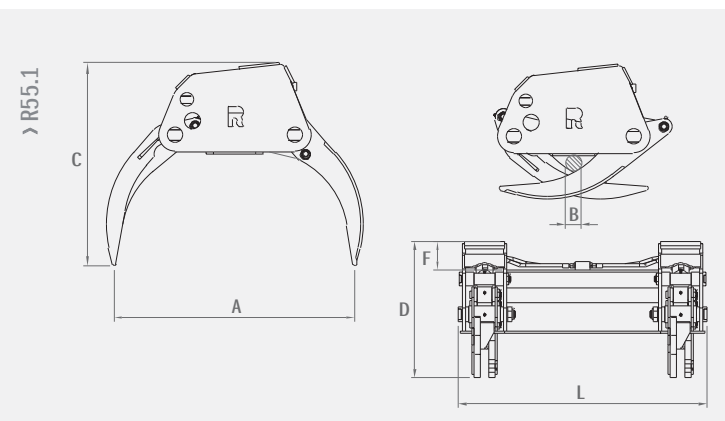
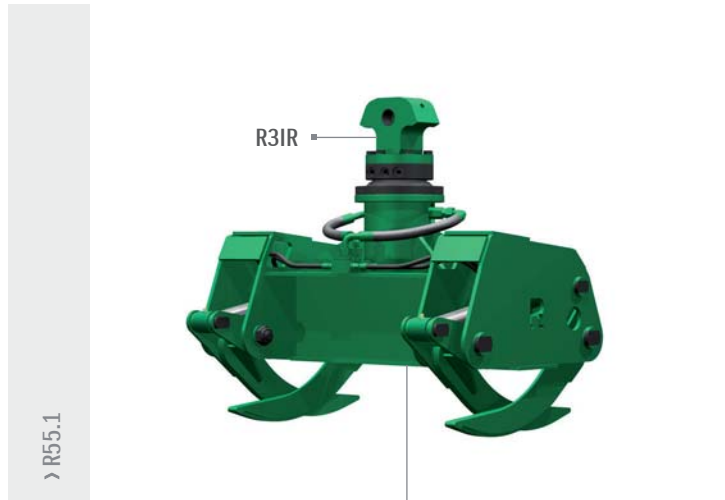

Modello	Portata	Peso	Pressione	Portata olio	Dimensioni					
Model	Lifting capacity	Weight	Pressure	Oil flow	Sizes					
Modèle	Portée	Poids	Pression	Débit d'huile	Dimensions					
Modell	Tragkraft	Gewicht	Druck	Ölleistung	Abmessungen					
	Kg	kg	bar	l/min	A	B	C	D	L	F
R55.1	3500	460	280	70	1200	80	1020	670	1230	140
R55.2	5000	470	280	120	1150	250	900	1180	1200	360
R56	8000	1280	280	200	1500	365	1560	1810	1600	670



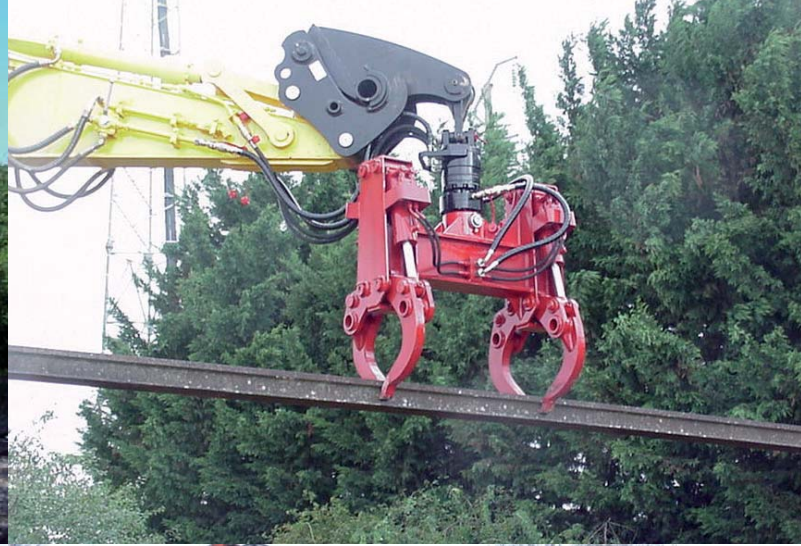

**BENNE BIVALVE**



Le benne bivalve sono attrezzature idrauliche disponibili in due categorie principali: **da scavo**: con cilindri verticali e profilo delle pale progettato per assicurare l'elevata penetrazione; **da carico**: con cilindri orizzontali in modo da ridurre l'ingombro in altezza e con geometria delle pale ottimizzata per ottenere il massimo riempimento. La versione da carico è utilizzabile per la movimentazione di: terra, sabbia, ghiaia, CDR, fanghi, cereali, carbone, fertilizzanti, scarti industriali e agricoli, minerali, ecc. Tutti i modelli possono essere forniti con o senza denti e con dispositivo di rotazione. La carpenteria ed i cilindri sono realizzati con materiali di elevata qualità e resistenza mentre le lame, soggette ad abrasione, sono in acciaio antiusura HB400/500. I perni e le boccole sono costruiti con acciai speciali con trattamento termico di indurimento, in modo da garantire una lunga durata anche in condizioni gravose e con scarsa lubrificazione.



**CLAMSHELL BUCKETS**

Clamshell buckets are hydraulic equipment which are available in two main categories: **for digging**: with vertical cylinders and the profile of the tines is designed to ensure a high penetration; **for loading**: with horizontal cylinders so as to reduce the overall height and geometric design of the tines allows maximum filling. The loading version is used for the movement of earth, sand, gravel, RDF, mud, cereals, coal, fertilizers, industrial and agricultural waste, minerals, etc.. All models can be supplied with or without teeth and equipped with hydraulic rotator. The steelwork and cylinders are made of high quality and durable materials while the blades, which are subject to abrasion, are in wear-resistant steel HB400/500. The pins and the bushings are made of special steel with heat treatment for hardening, so as to ensure a long life even under severe conditions and with poor lubrication.

**BENNES**

Les bennes preneuses sont des équipements hydrauliques disponibles en deux catégories principales: **de terrassement**: avec des vérins verticaux et un profil de coquilles conçu pour assurer une bonne pénétration; **de chargement**: avec des vérins horizontaux de façon à réduire l'encombrement en hauteur et avec une forme de coquilles optimale pour un remplissage maximal. La version de chargement est utilisée pour la manipulation de: terre, sable, gravier, RDF, boue, céréales, charbon, engrais, déchets industriels et agricoles, minéraux, etc. Tous les modèles peuvent être livrés avec ou sans dents et avec un dispositif de rotation. La structure et les vérins sont réalisés avec des matériaux de haute qualité et durabilité, tandis que les lames, qui sont soumises à l'abrasion, sont en acier résistant à l'usure HB400/500. Les axes et les bagues sont en acier spécial avec un traitement thermique de durcissement, de manière à assurer une longue durée de vie même dans des conditions difficiles et avec une mauvaise lubrification.

-  Esempi di applicazione
-  Examples of application
-  Exemples d'application

-  Anwendungsbeispiele
-  Ejemplos de aplicacion
-  Примеры комплектации

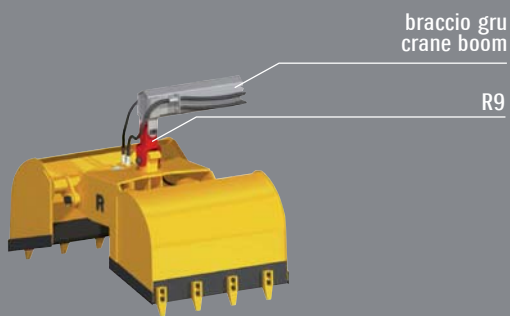
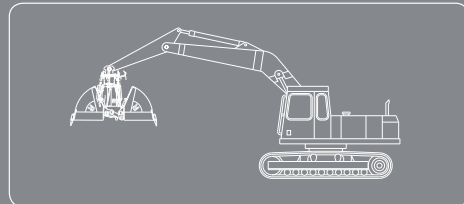
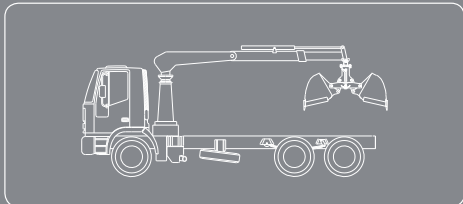

braccio gru  
crane boom

R9

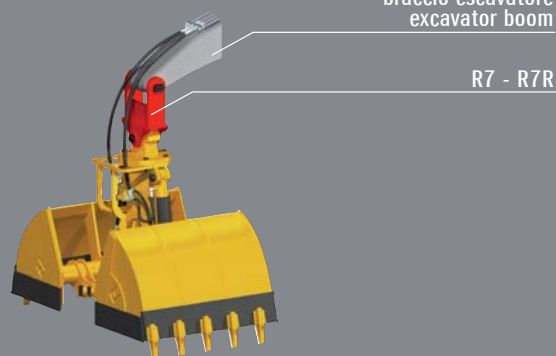

braccio escavatore  
excavator boom

R7 - R7R

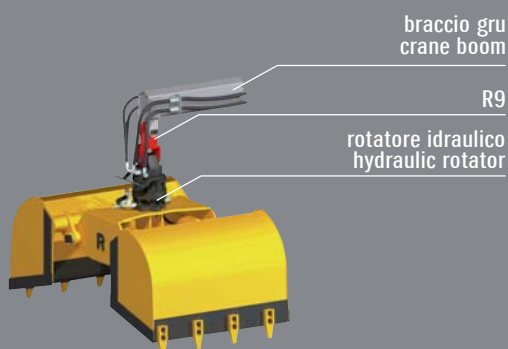

braccio gru  
crane boom

R9

rotatore idraulico  
hydraulic rotator

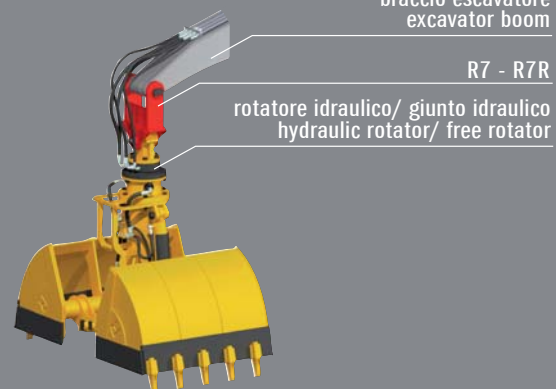

braccio escavatore  
excavator boom

R7 - R7R

rotatore idraulico/ giunto idraulico  
hydraulic rotator/ free rotator

## ZWEISCHALENGREIFER



Zweischalengreifer sind hydraulische Ausrüstungen für zwei grundlegende Einsatzgebiete: **für den Aushub**: mit vertikalen Zylindern und einer Schalenform, die ein bestmögliches Eindringen in das Material garantiert; **für die Verladung**: mit Horizontalzylindern zur Reduzierung der Bauhöhe sowie mit Schalen, die für ein optimales Be- und Entladen sorgen. Diese Greifer sind geeignet für den Umschlag von Erdböden, Sand, Kies, RDF, Schotter, Schlamm, Getreide, Kohle, Düngemitteln, Industrie- und Landwirtschaftsabfällen, Mineralstoffen u.s.w. Alle Modelle können mit Drehmotoren ausgestattet werden. Die Stahlkonstruktion und die Zylinder werden aus hochwertigem Material gefertigt und die Schneiden, die einem besonders starken Abrieb ausgesetzt sind, aus verschleißfestem Stahl HB 400/500. Die Bolzen und Buchsen sind aus Spezialstahl mit thermischer Härtebehandlung, um auch unter schwierigsten Bedingungen und trotz unzureichender Schmierung eine lange Lebensdauer zu gewährleisten.



## BIVALVAS

Los bivalvas son equipos hidráulicos disponibles en dos modelos, según sus usos: **para excavación**: utilizan cilindros verticales y perfiles de excavación para las palas diseñados para asegurar una mayor penetración; **para carga**: incorporan cilindros horizontales destinados a rebajar su altura y una disposición de las palas optimizada para tener total capacidad de relleno de las mismas. Dicho modelo es empujado para mover tierra, grava, barros, cereales, carbón, fertilizantes y gran variedad de residuos tanto industriales como agrícolas, minerales, etc. Todos los modelos se encuentran disponibles con o sin dientes y con rotator integrado. La construcción de los cilindros está hecha con materiales de la más alta calidad y resistencia sostenida. Las lamas expuestas a desgaste por abrasión están fabricadas en acero HB400/500 para evitar su pronto desgaste y alargar su vida útil. Pernos y ejes están fabricados con aceros especiales y con tratamientos térmicos de endurecimiento para garantizar su longevidad incluso en situaciones con poca lubricación.



## ДВУХЧЕЛЮСТНЫЕ ГРЕЙФЕРЫ

Двухчелюстные грейферы – это гидравлическое оборудование, которое подразделяется на две основные категории: **Для копания**: вертикальные цилиндры и форма зубьев спроектированы для обеспечения наиболее глубокого вскапывания. **для погрузки**: с горизонтальными цилиндрами для уменьшения общей высоты и геометрической формой лепестков для максимального захвата. Данные грейферы используются для перемещения земли, песка, гравия, грязи, злаков, угля, удобрений, промышленных и сельскохозяйственных отходов, минералов и тд. Все модели могут поставляться как с зубьями, так и без них, а также оборудоваться гидравлическим ротатором. Стальная конструкция и цилиндры выполнены из высококачественных износостойких материалов, в то время как лопасти, подверженные износу, выполнены из износостойкой стали HB400/500. Пальцы и втулки сделаны из специальной закаленной стали, которые долго служат даже при тяжелых условиях и при недостатке смазки.

 Schemi utilizzo per benne bivalve  
 Scheme of use for grabs  
 Schéma d'emploi pour bennes

 Anwendungsübersicht für Zweischalengreifer  
 Esquema de uso para bivalvas  
 Схема использования грейферов

Benne bivalve Clamshell buckets	Gancio Hook	Giunto idraulico Free rotator	Rotatore idraulico Hydraulic rotator	Peso escavatore / caricatore Excavator / loader weight
R30/80 - 110	R9	***	R102	1.5 - 2.5
R41/145 - 155	R9	***	R102	2 - 3
R30/125 - 140 - 160 - 180	R9	***	R103 - R104	3 - 6
R30/240 - 260 - 290	R9	***	R103 - R104	4 - 7
R74/200 - 250 - 300 - 400 - 500	R9	***	R103 - R104 - R105	4 - 7
R74/200AF - 250AF - 300AF - 400AF - 500AF	R9	***	R103 - R104 - R105	4 - 7
R75/300 - 400 - 500 - 600	R9	***	R103 - R104 - R105	4 - 7
R40/100	R9 - R7	***	R05 - R105 - R105H - R1G	7 - 14
R41/300 - 400 - 500	R9 - R7	***	R05 - R105H - R1G	6 - 12
R30/340 - 360 - 380	R9 - R7	R2	R05 - R105 - R105H - R1G	6 - 14
R31/400 - 600 - 800	R7	R2 - R2IR10	R3IR - R1G	9 - 18
R41/700 - 1000 - 1200	R7 - R7R	R2 - R2A - R2IR10	R3IR - R1G - R4G	12 - 20
R32/500 - 600 - 700 - 800	R7 - R7R	R2A - R2IR10	R3IR - R1G - R4G	14 - 22
R40/1200 - 1500 - 1700	R7 - R7R	R2A - R2BIR20	R3BIR - R4G	18 - 26
R34/800 - 1000 - 1300 - 1500	R7 - R7R	R2A - R2BIR20	R3BIR - R4G	20 - 32
R34/1000C - 1300C - 1500C	R7 - R7R	R2A - R2BIR20	R3BIR - R4G	22 - 32
R35/1350 - 1500 - 1700	R7R	R2C	R3C - R5G	30 - 50
R42/3000H - 4000H - 5000H	R7R	R2C (only 3000)	R3C (only 3000) - R5G	35 - 50
R43/5000H - 6000H - 7000H - 8000H	R7R	***	R5G	35 - 50
30 Ø800 - Ø1000	R7	R2 - R2IR10	R3IR - R1G	8 - 16
R32 Ø1200 - Ø1400	R7	R2A - R2IR10	R3IR	14 - 22



 Benne bivalente per scavo e carico materiali vari  
 Grabs for digging and different materials' loading  
 Bennes double-coquilles pour l'excavation et le chargement de matériaux divers

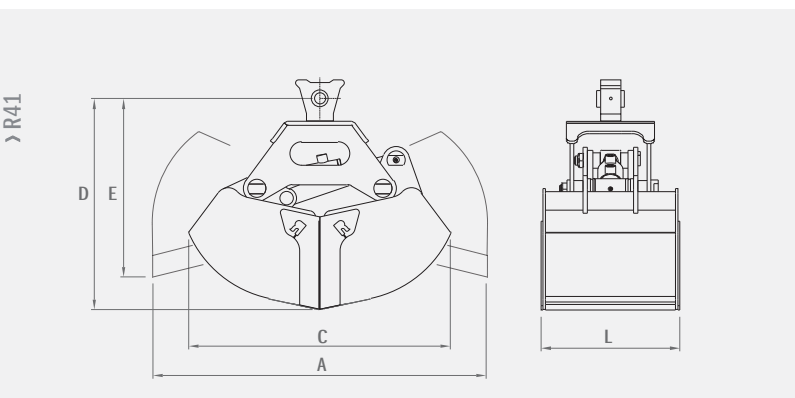
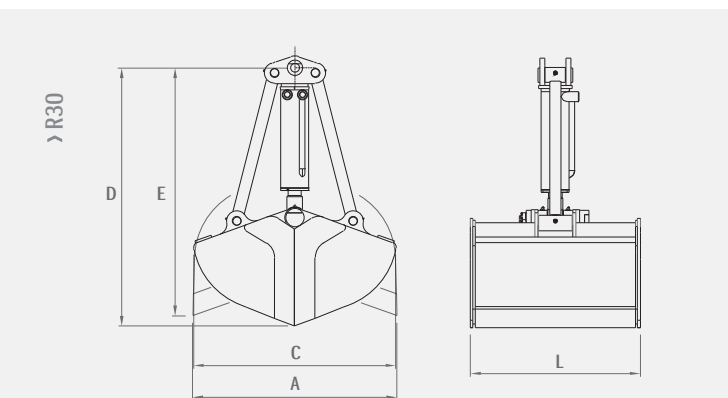
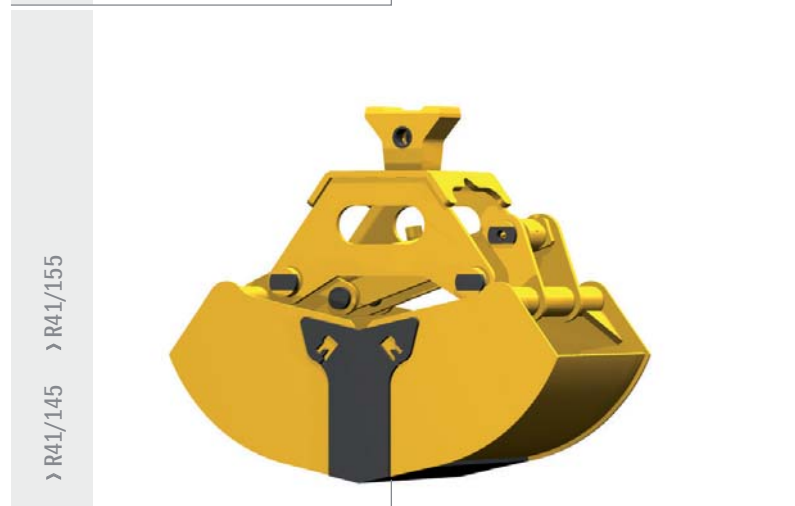
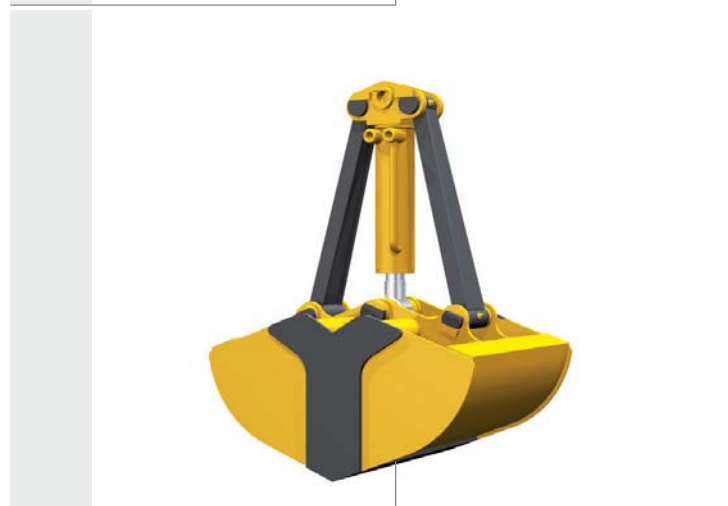
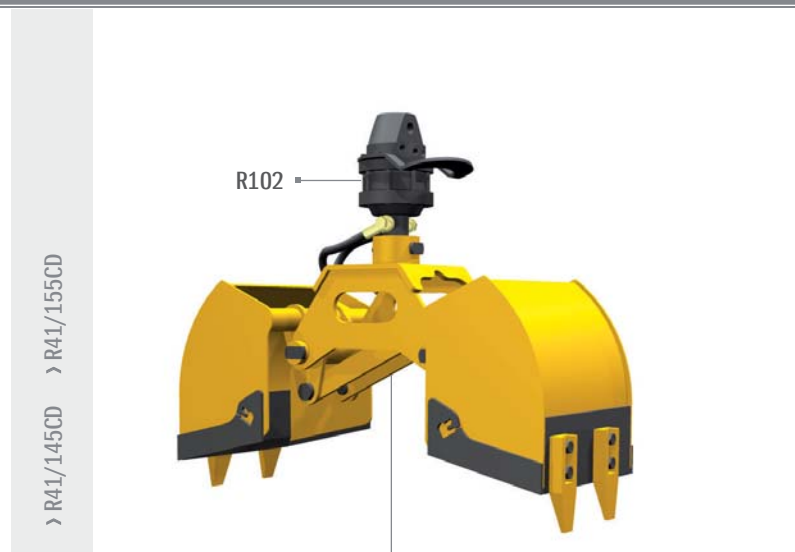
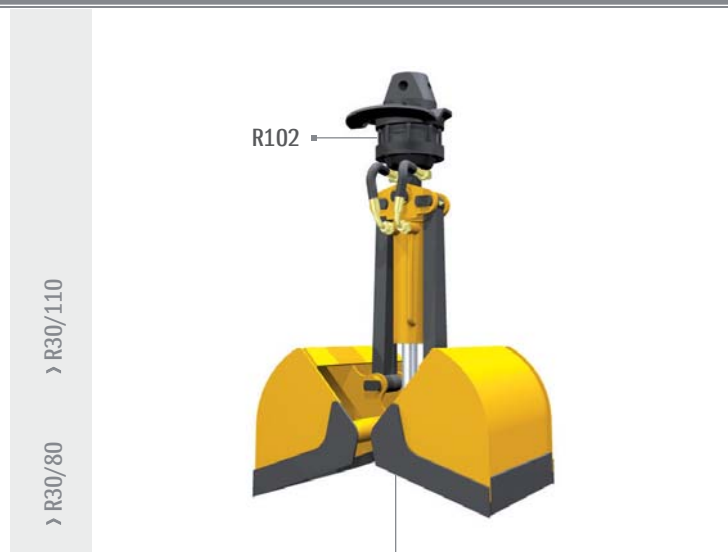

 Zweischalengreifer für Aushub und Verladung von verschiedenen Materialien  
 Bivalvas para excavación y carga de materiales diversos  
 Двухчелюстной грейфер для сыпучих материалов



Modello	Capacità	Peso	Pressione	Portata olio	Forza alla lama	Dimensioni				
Model	Capacity	Weight	Pressure	Oil flow	Tine force	Sizes				
Modèle	Capacité	Poids	Pression	Débit d'huile	Puissance à la lame	Dimensions				
Modell	Inhalt	Gewicht	Druck	Ölleistung	Schließkraft je Schale	Abmessungen				
	dm <sup>3</sup>	kg	bar	l/min	Kg	A	C	D	E	L
R30/80	30	65	280	30	2030	600	595	760	730	300
R30/110	50	80	280	30	2030	600	595	760	730	500
R41/145	60	110	280	20	930	990	780	630	530	410
R41/155	95	130	280	20	930	990	780	630	530	610



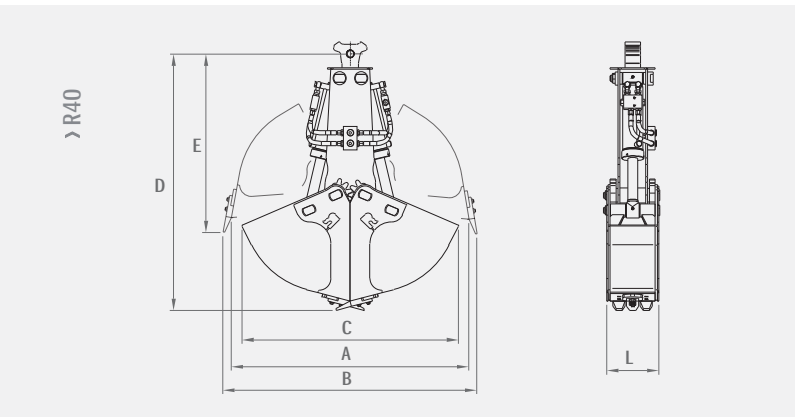
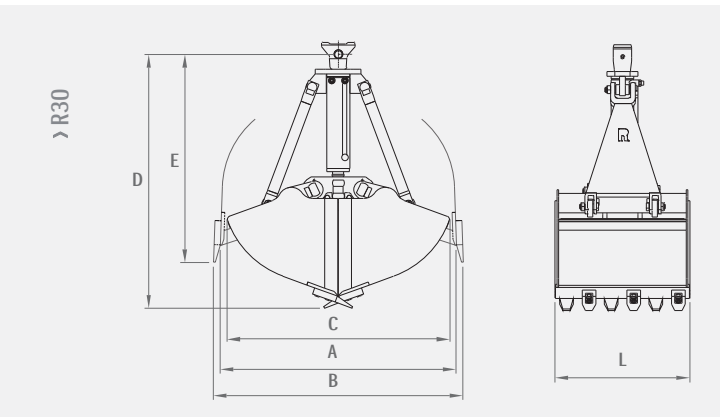
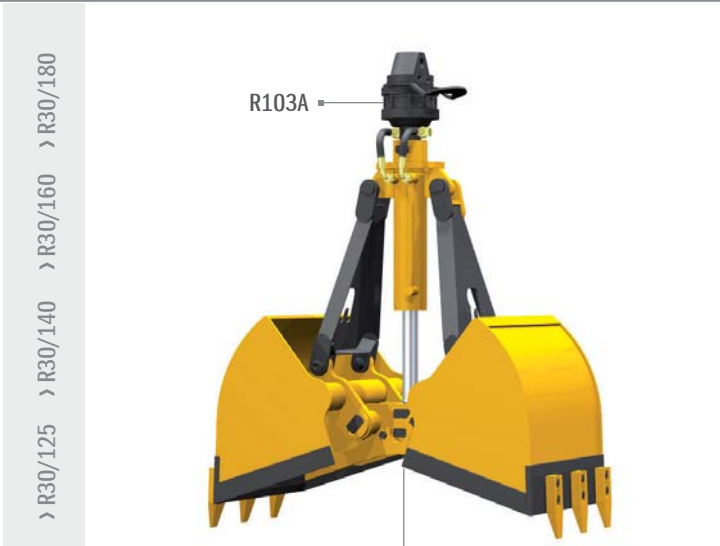

 Benne bivalente per scavo e carico materiali vari  
 Grabs for digging and different materials' loading  
 Bennes double-coquilles pour l'excavation et le chargement de matériaux divers

 Zweischalengreifer für Aushub und Verladung von verschiedenen Materialien  
 Bivalvas para excavación y carga de materiales diversos  
 Двухчелостной грейфер для сыпучих материалов



Modello	Capacità	Peso	Pressione	Portata olio	Forza alla lama	Dimensioni					
Model	Capacity	Weight	Pressure	Oil flow	Tine force	Sizes					
Modèle	Capacité	Poids	Pression	Débit d'huile	Puissance à la lame	Dimensions					
Modell	Inhalt	Gewicht	Druck	Ölleistung	Schließkraft je Schale	Abmessungen					
	dm <sup>3</sup>	kg	bar	l/min	Kg	A	B	C	D	E	L
R30/125	70	170	280	70	2800	1080	1140	1020	1160	1220	260
R30/140	110	190	280	70	2800	1080	1140	1020	1160	1220	410
R30/160	170	230	280	70	2800	1080	1140	1020	1160	1220	610
R30/180	230	260	280	70	2800	1080	1140	1020	1160	1220	810
R40/100	100	250	250	90	4150	1200	1300	1100	1300	900	270

 Benne bivalve per carico materiali vari  
 Grabs for different materials' loading  
 Bennes double-coquilles pour le chargement de matériaux divers

 Zweischalengreifer für Verladung von verschiedenen Materialien  
 Bivalvas para carga de materiales diversos  
 Грейфер для погрузки различных материалов

> R30

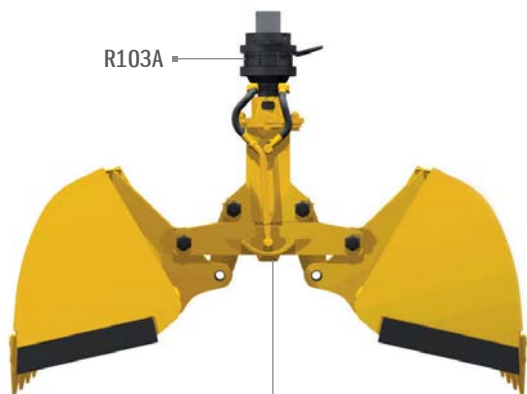

R103A

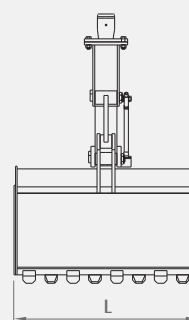
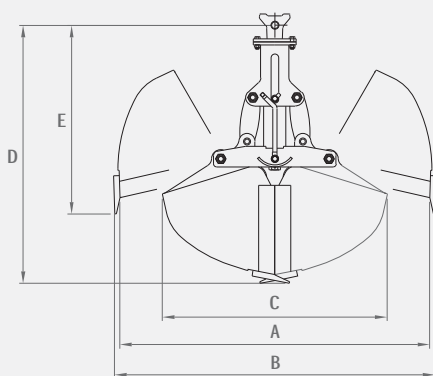
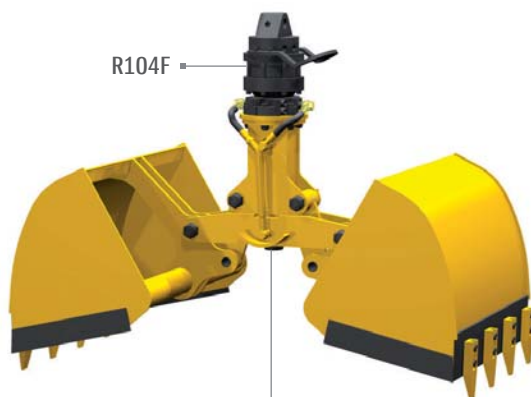

R104F



Modello	Capacità	Peso	Pressione	Portata olio	Forza alla lama	Dimensioni					
Model	Capacity	Weight	Pressure	Oil flow	Tine force	Sizes					
Modèle	Capacité	Poids	Pression	Débit d'huile	Puissance à la lame	Dimensions					
Modell	Inhalt	Gewicht	Druck	Ölleistung	Schließkraft je Schale	Abmessungen					
	dm <sup>3</sup>	kg	bar	l/min	Kg	A	B	C	D	E	L
R30/240	130	210	280	50	1730	1550	1600	1120	1290	940	400
R30/260	215	260	280	50	1730	1550	1600	1120	1290	940	670
R30/290	300	300	280	50	1730	1550	1600	1120	1290	940	915



-  Benne bivalente per carico materiali vari
-  Grabs for different materials' loading
-  Bennes double-coquilles pour le chargement de matériaux divers

-  Zweischalengreifer für Verladung von verschiedenen Materialien
-  Bivalvas para carga de materiales diversos
-  Грейфер для погрузки различных материалов

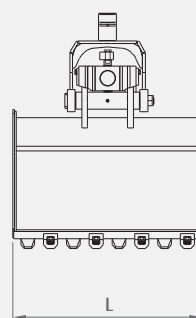
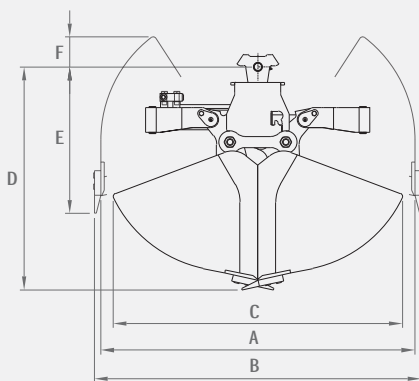
> R74



Modello	Capacità	Peso	Pressione	Portata olio	Forza alla lama	Dimensioni						
Model	Capacity	Weight	Pressure	Oil flow	Tine force	Sizes						
Modèle	Capacité	Poids	Pression	Débit d'huile	Puissance à la lame	Dimensions						
Modell	Inhalt	Gewicht	Druck	Ölleistung	Schließkraft je Schale	Abmessungen						
	dm <sup>3</sup>	kg	bar	l/min	Kg	A	B	C	D	E	F	L
R74/200	200	280	300	70	2470	1400	1460	1300	990	650	135	450
R74/250	250	295	300	70	2470	1400	1460	1300	990	650	135	550
R74/300	300	310	300	70	2470	1400	1460	1300	990	650	135	650
R74/400	400	340	300	70	2470	1400	1460	1300	990	650	135	850
R74/500	500	370	300	70	2470	1400	1460	1300	990	650	135	1000



-  Benne bivalente per carico materiali vari
-  Grabs for different materials' loading
-  Bennes double-coquilles pour le chargement de matériaux divers

-  Zweischalengreifer für Verladung von verschiedenen Materialien
-  Bivalvas para carga de materiales diversos
-  Грейфер для погрузки различных материалов

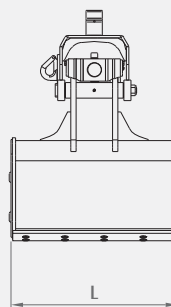
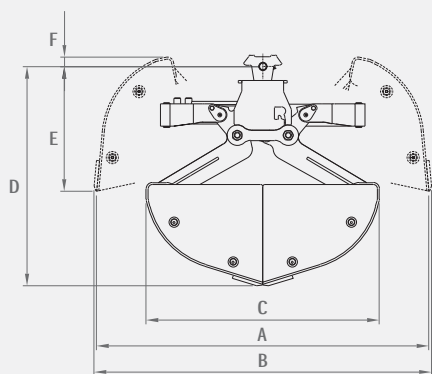
R74AF



Modello	Capacità	Peso	Pressione	Portata olio	Forza alla lama	Dimensioni						
Model	Capacity	Weight	Pressure	Oil flow	Tine force	Sizes						
Modèle	Capacité	Poids	Pression	Débit d'huile	Puissance à la lame	Dimensions						
Modell	Inhalt	Gewicht	Druck	Ölleistung	Schließkraft je Schale	Abmessungen						
	dm <sup>3</sup>	kg	bar	l/min	Kg	A	B	C	D	E	F	L
R74/200 AF	200	310	300	70	2350	1630	1655	1150	1075	610	50	420
R74/250 AF	250	325	300	70	2350	1630	1655	1150	1075	610	50	520
R74/300 AF	300	340	300	70	2350	1630	1655	1150	1075	610	50	620
R74/400 AF	400	370	300	70	2350	1630	1655	1150	1075	610	50	820
R74/500 AF	500	400	300	70	2350	1630	1655	1150	1075	610	50	1020

 Benne bivalente per carico materiali vari  
 Grabs for different materials' loading  
 Bennes double-coquilles pour le chargement de matériaux divers

 Zweischalengreifer für Verladung von verschiedenen Materialien  
 Bivalvas para carga de materiales diversos  
 Грейфер для погрузки различных материалов

> R75



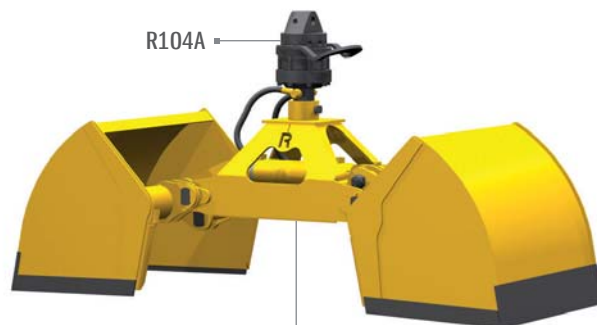

R104F

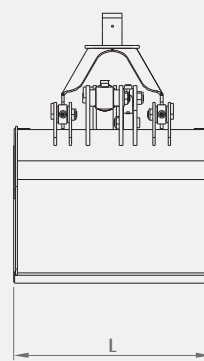
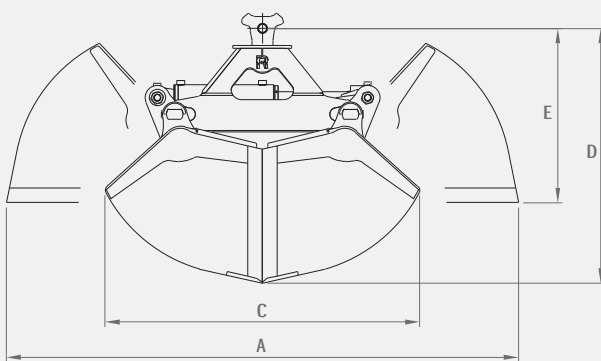

R104A



Modello	Capacità	Peso	Pressione	Portata olio	Forza alla lama	Dimensioni				
Model	Capacity	Weight	Pressure	Oil flow	Tine force	Sizes				
Modèle	Capacité	Poids	Pression	Débit d'huile	Puissance à la lame	Dimensions				
Modell	Inhalt	Gewicht	Druck	Ölleistung	Schließkraft je Schale	Abmessungen				
	dm <sup>3</sup>	kg	bar	l/min	Kg	A	C	D	E	L
<b>R75/300</b>	300	280	280	70	2050	2100	1300	1060	735	500
<b>R75/400</b>	400	305	280	70	2050	2100	1300	1060	735	650
<b>R75/500</b>	500	330	280	70	2050	2100	1300	1060	735	800
<b>R75/600</b>	600	365	280	70	2050	2100	1300	1060	735	1000



 Benne bivalve per carico materiali vari  
 Grabs for different materials' loading  
 Bennes double-coquilles pour le chargement de matériaux divers

 Zweischalengreifer für Verladung von verschiedenen Materialien  
 Bivalvas para carga de materiales diversos  
 Грейфер для погрузки различных материалов

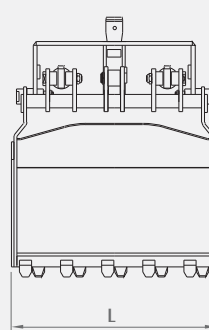
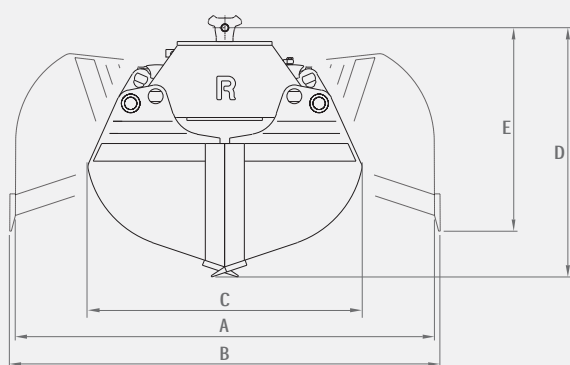
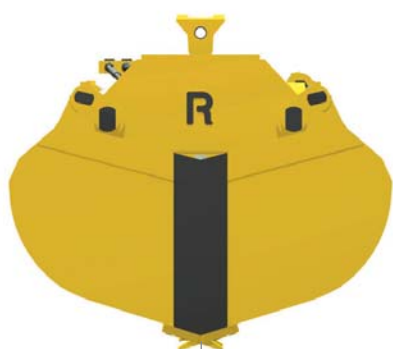
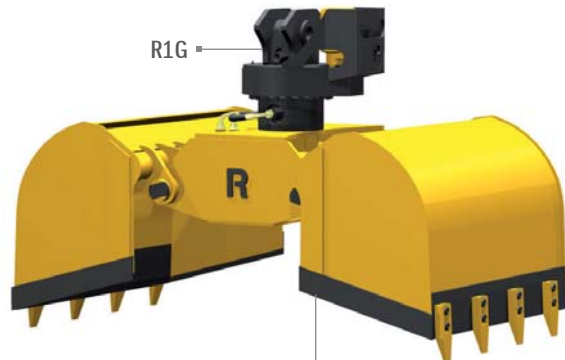
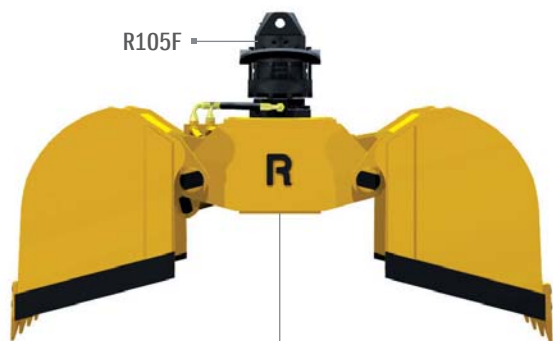
&gt; R41





Modello	Capacità	Peso	Pressione	Portata olio	Forza alla lama	Dimensioni					
Model	Capacity	Weight	Pressure	Oil flow	Tine force	Sizes					
Modèle	Capacité	Poids	Pression	Débit d'huile	Puissance à la lame	Dimensions					
Modell	Inhalt	Gewicht	Druck	Ölleistung	Schließkraft je Schale	Abmessungen					
	dm <sup>3</sup>	kg	bar	l/min	Kg	A	B	C	D	E	L
R41/300	280	330	280	40	1975	1650	1740	1140	940	780	590
R41/400	380	430	280	80	3950	1650	1740	1140	940	780	825
R41/500	480	465	280	80	3950	1650	1740	1140	940	780	1020
R41/700	500	680	280	100	4400	1990	2070	1270	1230	1070	840
R41/1000	750	830	280	100	4060	2140	2220	1400	1320	1100	1020
R41/1200	900	910	280	100	4060	2140	2220	1400	1320	1100	1250

 Benne bivalve per scavo e carico materiali vari  
 Grabs for digging and different materials' loading  
 Bennes double-coquilles pour l'excavation et le chargement de matériaux divers

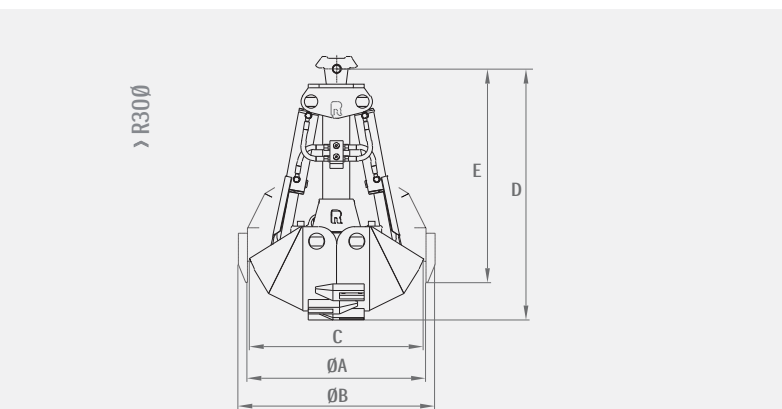
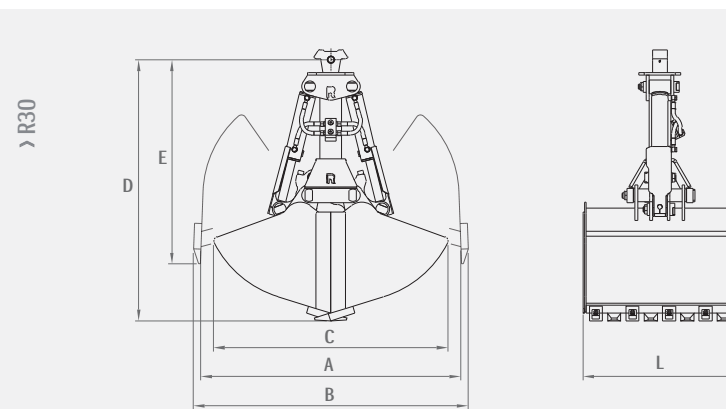
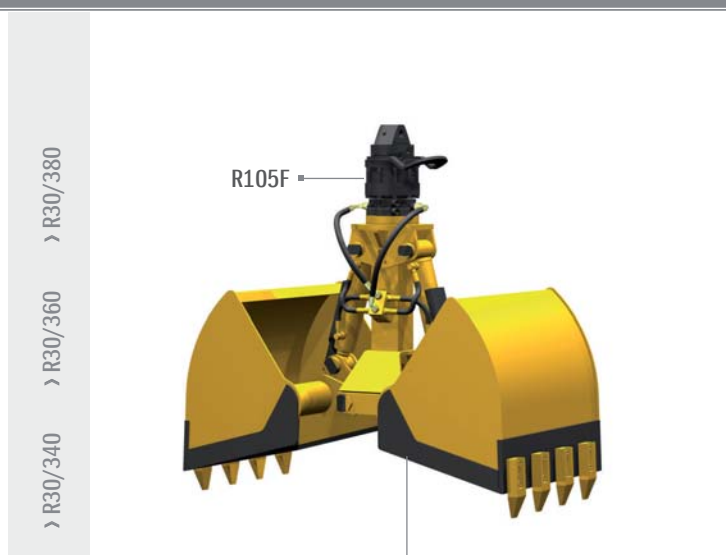
 Zweischalengreifer für Aushub und Verladung von verschiedenen Materialien  
 Bivalvas para excavación y carga de materiales diversos  
 Двухчелюстной грейфер для сыпучих материалов



Modello	Capacità	Peso	Pressione	Portata olio	Forza alla lama	Dimensioni					
Model	Capacity	Weight	Pressure	Oil flow	Tine force	Sizes					
Modèle	Capacité	Poids	Pression	Débit d'huile	Puissance à la lame	Dimensions					
Modell	Inhalt	Gewicht	Druck	Ölleistung	Schließkraft je Schale	Abmessungen					
	dm <sup>3</sup>	kg	bar	l/min	Kg	A	B	C	D	E	L
R30/340	180	340	300	60	3200	1420	1500	1280	1440	1130	440
R30/360	260	380	300	60	3200	1420	1500	1280	1440	1130	640
R30/380	340	420	300	60	3200	1420	1500	1280	1440	1130	840
R30Ø800	90	350	300	60	5900	800	880	780	1130	970	
R30Ø1000	140	420	300	60	4500	1000	1080	950	1230	970	

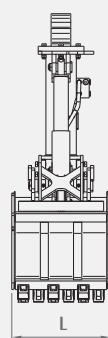
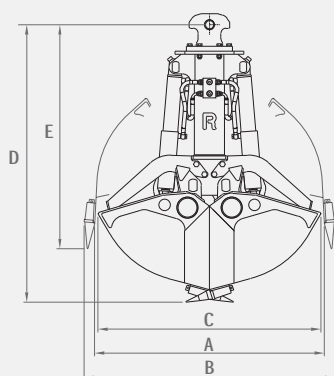
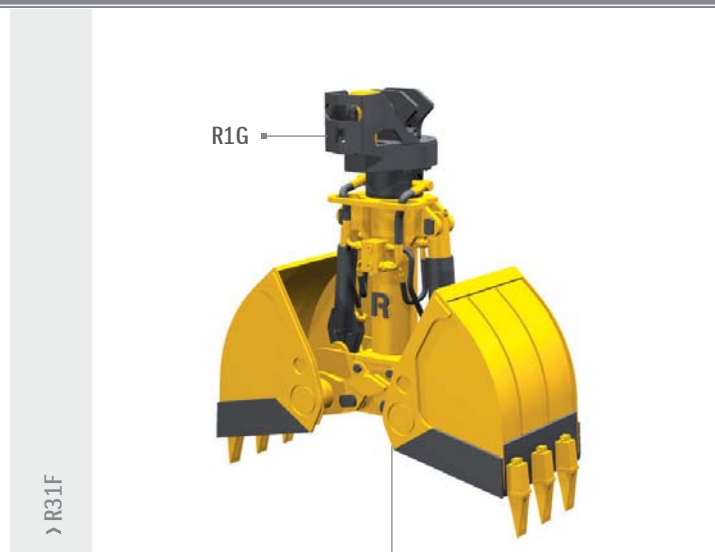

 Benne bivalente per scavo e carico materiali vari  
 Grabs for digging and different materials' loading  
 Bennes double-coquilles pour l'excavation et le chargement de matériaux divers

 Zweischalengreifer für Aushub und Verladung von verschiedenen Materialien  
 Bivalvas para excavación y carga de materiales diversos  
 Двухчелюстной грейфер для сыпучих материалов



Modello	Capacità	Peso	Pressione	Portata olio	Forza alla lama	Dimensioni					
Model	Capacity	Weight	Pressure	Oil flow	Tine force	Sizes					
Modèle	Capacité	Poids	Pression	Débit d'huile	Puissance à la lame	Dimensions					
Modell	Inhalt	Gewicht	Druck	Ölleistung	Schließkraft je Schale	Abmessungen					
	dm <sup>3</sup>	kg	bar	l/min	Kg	A	B	C	D	E	L
R31F400	170	530	300	90	4350	1400	1530	1360	1670	1340	400
R31/400	170	550	300	90	4350	1400	1530	1360	1670	1340	400
R31F600	270	580	300	90	4350	1400	1530	1360	1670	1340	600
R31/600	270	600	300	90	4350	1400	1530	1360	1670	1340	600
R31F800	370	630	300	90	4350	1400	1530	1360	1670	1340	800
R31/800	370	650	300	90	4350	1400	1530	1360	1670	1340	800



 Benne bivalente per scavo e carico materiali vari  
 Grabs for digging and different materials' loading  
 Bennes double-coquilles pour l'excavation et le chargement de matériaux divers

 Zweischalengreifer für Aushub und Verladung von verschiedenen Materialien  
 Bivalvas para excavación y carga de materiales diversos  
 Двухчелюстной грейфер для сыпучих материалов

> R32/500 > R32/600 > R32/700 > R32/800

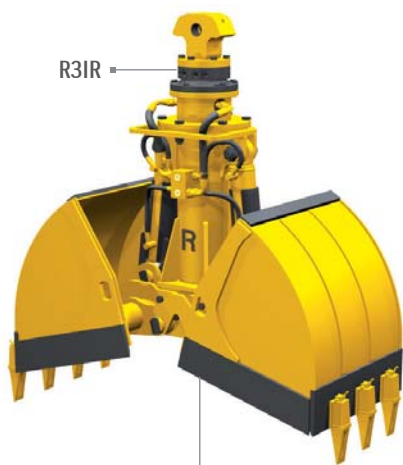

R3IR

> R32Ø1200 > R32Ø1400



R4G



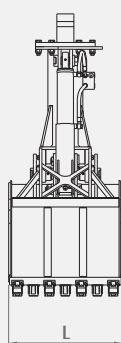
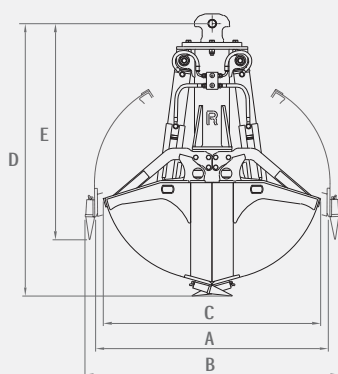

> R32

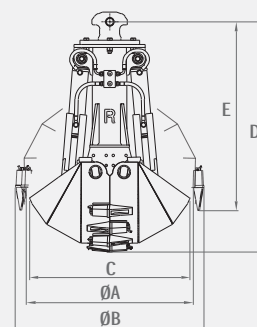

> R32Ø



Modello	Capacità	Peso	Pressione	Portata olio	Forza alla lama	Dimensioni					
Model	Capacity	Weight	Pressure	Oil flow	Tine force	Sizes					
Modèle	Capacité	Poids	Pression	Débit d'huile	Puissance à la lame	Dimensions					
Modell	Inhalt	Gewicht	Druck	Ölleistung	Schließkraft je Schale	Abmessungen					
	dm <sup>3</sup>	kg	bar	l/min	Kg	A	B	C	D	E	L
R32/500	315	775	300	120	5920	1650	1780	1510	1910	1500	500
R32/600	385	800	300	120	5920	1650	1780	1510	1910	1500	600
R32/700	455	825	300	120	5920	1650	1780	1510	1910	1500	700
R32/800	525	850	300	120	5920	1650	1780	1510	1910	1500	800
R32Ø1200	220	830	300	120	9150	1200	1330	1070	1610	1300	
R32Ø1400	390	950	300	120	7650	1400	1530	1270	1710	1300	

 Benne bivalve per scavo e carico materiali vari  
 Grabs for digging and different materials' loading  
 Bennes double-coquilles pour l'excavation et le chargement de matériaux divers

 Zweischalengreifer für Aushub und Verladung von verschiedenen Materialien  
 Bivalvas para excavación y carga de materiales diversos  
 Двухчелюстной грейфер для сыпучих материалов

&gt; R34



R3BIR

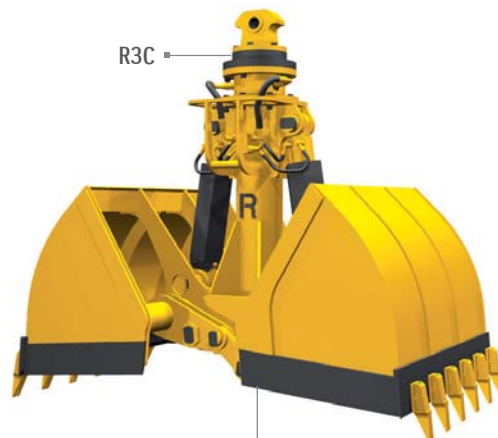

&gt; R35



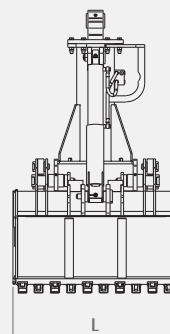
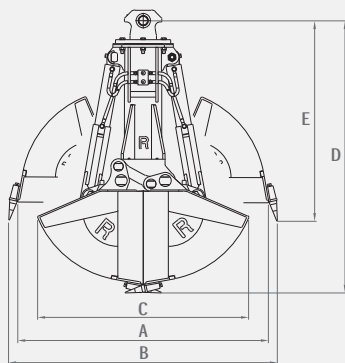

R3C



Modello	Capacità	Peso	Pressione	Portata olio	Forza alla lama	Dimensioni					
Model	Capacity	Weight	Pressure	Oil flow	Tine force	Sizes					
Modèle	Capacité	Poids	Pression	Débit d'huile	Puissance à la lame	Dimensions					
Modell	Inhalt	Gewicht	Druck	Ölleistung	Schließkraft je Schale	Abmessungen					
	dm <sup>3</sup>	kg	bar	l/min	Kg	A	B	C	D	E	L
<b>R34/800</b>	700	1200	300	160	8000	2000	2140	1680	2130	1570	800
<b>R34/1000</b>	880	1320	300	160	8000	2000	2140	1680	2130	1570	1000
<b>R34/1300</b>	1150	1440	300	160	8000	2000	2140	1680	2130	1570	1300
<b>R34/1500</b>	1325	1550	300	160	8000	2000	2140	1680	2130	1570	1500
<b>R35/1350</b>	1850	2550	300	260	11260	2570	2750	2310	2820	2060	1350
<b>R35/1500</b>	2150	2600	300	260	11260	2570	2750	2310	2820	2060	1500
<b>R35/1700</b>	2450	2650	300	260	11260	2570	2750	2310	2820	2060	1700

 Benne bivalente per carico materiali vari  
 Grabs for different materials' loading  
 Bennes double-coquilles pour le chargement de matériaux divers

 Zweischalengreifer für Verladung von verschiedenen Materialien  
 Bivalvas para carga de materiales diversos  
 Грейфер для погрузки различных материалов

> R40



> R34C

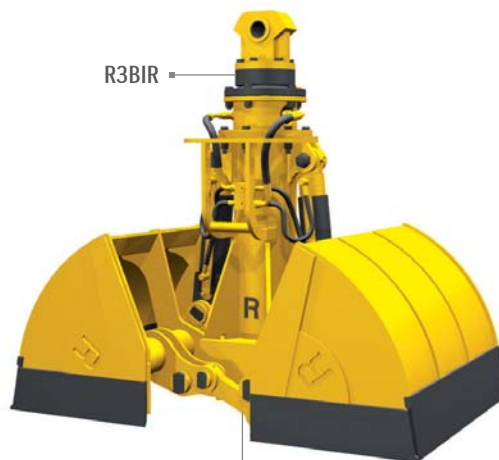

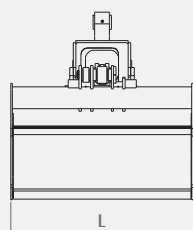
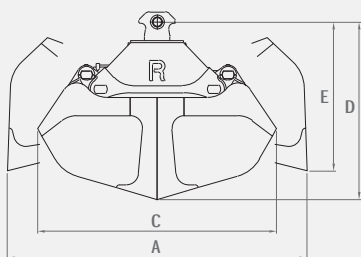

> R40

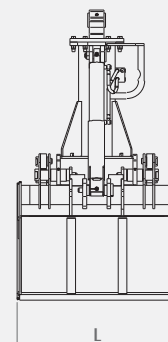
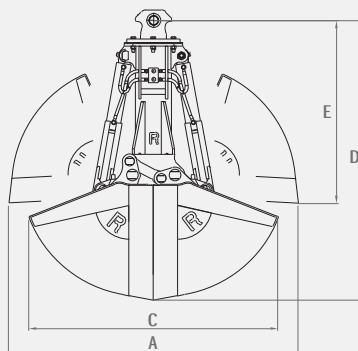

> R34C



Modello	Capacità	Peso	Pressione	Portata olio	Forza alla lama	Dimensioni				
Model	Capacity	Weight	Pressure	Oil flow	Tine force	Sizes				
Modèle	Capacité	Poids	Pression	Débit d'huile	Puissance à la lame	Dimensions				
Modell	Inhalt	Gewicht	Druck	Ölleistung	Schließkraft je Schale	Abmessungen				
	dm <sup>3</sup>	kg	bar	l/min	Kg	A	C	D	E	L
R40/1200	1260	1210	300	100	4760	2460	1960	1300	1070	1200
R40/1500	1580	1345	300	100	4760	2460	1960	1300	1070	1500
R40/1700	1800	1420	300	100	4760	2460	1960	1300	1070	1700
R34/1000C	1330	1320	300	160	6500	2400	2040	2270	1420	1000
R34/1300C	1750	1440	300	160	6500	2400	2040	2270	1420	1300
R34/1500C	2000	1520	300	160	6500	2400	2040	2270	1420	1500

 Benne bivalve per carico materiali vari  
 Grabs for different materials' loading  
 Bennes double-coquilles pour le chargement de matériaux divers

 Zweischalengreifer für Verladung von verschiedenen Materialien  
 Bivalvas para carga de materiales diversos  
 Грейфер для погрузки различных материалов

&gt; R42H



&gt; R43H



R5G

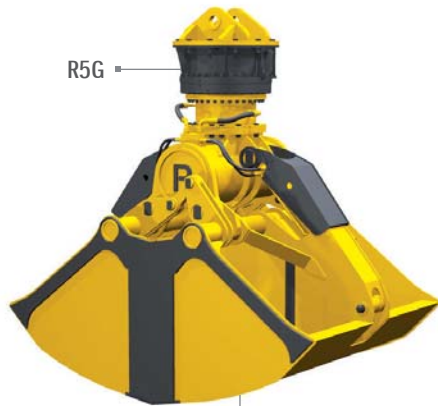

R5G



&gt; R42H

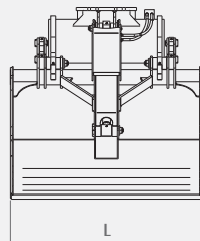
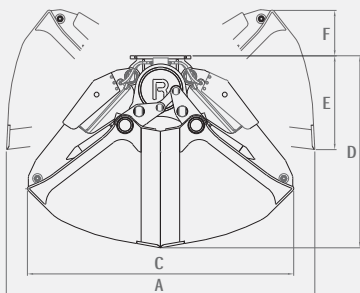

&gt; R43H

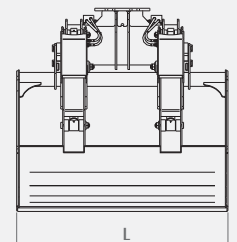
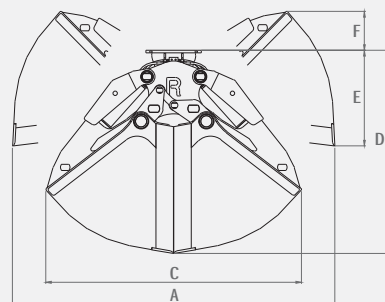

Modello	Capacità	Peso	Pressione	Portata olio	Forza alla lama	Dimensioni					
Model	Capacity	Weight	Pressure	Oil flow	Tine force	Sizes					
Modèle	Capacité	Poids	Pression	Débit d'huile	Puissance à la lame	Dimensions					
Modell	Inhalt	Gewicht	Druck	Ölleistung	Schließkraft je Schale	Abmessungen					
	dm <sup>3</sup>	kg	bar	l/min	Kg	A	C	D	E	F	L
R42/3000H	3000	2800	320	190	9500	3200	2750	2000	980	480	1500
R42/4000H	4000	3100	320	190	9500	3200	2750	2000	980	480	2000
R42/5000H	5000	3250	320	190	9500	3200	2750	2000	980	480	2500
R43/5000H	5000	4300	300	320	15300	3660	2910	2310	1090	435	2000
R43/6000H	6000	4500	300	320	15300	3660	2910	2310	1090	435	2400
R43/7000H	7000	4700	300	320	15300	3660	2910	2310	1090	435	2800
R43/8000H	8000	4900	300	320	15300	3660	2910	2310	1090	435	3200





## FORCHE E CESTE

Le forche sono attrezzature idrauliche realizzate per la movimentazione di ramaglie, fieno, paglia, letame, erba, scarti di giardinaggio, rifiuti agricoli e industriali. Sono costituite da due pale sincronizzate, azionate da uno o due cilindri, con applicati dei robusti denti in acciaio antiusura che assicurano la penetrazione e la presa del materiale. Le ceste sono utilizzate per il carico di bietole su gru da autocarro, escavatori e caricatori. Sono composte da un corpo centrale con due valvole incernierate, la cui particolare forma e costruzione permettono la presa del carico escludendo terra e sassi presenti al suolo. La serie CSL è una versione specifica per movimentazione di cippato impiegata in impianti di riciclaggio e lavorazione di scarti di legno. Robustezza, affidabilità, elevate prestazioni e durata sono garantiti dall' utilizzo di acciai speciali e da un' accurata progettazione. Forche e ceste possono essere equipaggiate con rotatori idraulici.

## FORKS AND BEET GRABS

The forks are hydraulically operated and specifically designed for the handling of waste wood, hay, straw, manure, grass, garden waste, agricultural waste and industrial waste. The grabs consist of two synchronized tines operated by one or two hydraulic cylinders. The grabs are fitted with heavy duty teeth manufactured from hard wearing steel to ensure long life, penetration and the holding of the materials. The beet grabs can be used by trucks, cranes, excavators and loaders. They are composed of a central body with two hinged tines whose shape and construction allow the load to be gripped while allowing earth and stones to remain on the ground. The CSL range is specially designed for the handling of wood chips used in the recycling and processing of waste wood. Robustness, reliability, high performance and durability are guaranteed by the use of special steels and successful design. Forks and beet grabs can be fitted with hydraulic rotators.

## FOURCHES ET BENNES À BETTERAVES

Les fourches sont des équipements hydrauliques réalisés pour le traitement des déchets du bois, du foin, de la paille, du fumier, de l'herbe, des déchets de jardin, des déchets agricoles et industriels. Elles sont constituées de deux coquilles synchronisées, actionnées par un ou deux vérins, avec des dents robustes en acier anti-usure qui assurent la pénétration et la prise des matériaux. Les bennes à betteraves sont utilisées pour le chargement de betteraves sur les camions-grues, et les pelles. Elles sont composées d'un corps central avec deux coquilles articulées, dont la forme et la construction particulière permettent la préhension de la charge en excluant la terre et les pierres présentes sur le terrain. La série CSL est une version spécifique pour le traitement des copeaux de bois, utilisée dans les installations de recyclage et de traitement des déchets du bois. Robustesse, fiabilité, hautes performances et durabilité sont garanties par l'utilisation d'aciers spéciaux et par une réalisation minutieuse. Les fourches et les bennes peuvent être équipées avec un rotator hydraulique.

## GABELN UND GREIFERKÖRBE



Gabeln sind hydraulische Ausrüstungen für den Umschlag von Reisig, Heu, Mist, Gartenabfällen sowie Landwirtschafts- und Industrieabfällen. Sie bestehen aus 2 sich synchron bewegenden Schalen mit einem oder zwei Zylindern und aus verschleißfesten robusten Stahlzähnen, die ein optimales Eindringen und Aufnahme des Materials gewährleisten. Die Greiferschalen werden für das Beladen von Rüben mit Ladekränen, Baggern und Ladern eingesetzt. Sie bestehen aus einem Grundkörper mit 2 gelenkigen Schalen. Die Form und die Konstruktion der Schalen ermöglichen den Umschlag der Ladung, ohne unnötiges Material wie Erde oder Steine aufzunehmen. Die Serie CSL ist eine spezielle Ausführung für den Umschlag von Holzspänen, die vor allem in Recyclinganlagen und in Verarbeitungsanlagen für Holzabfälle eingesetzt wird. Durch den Einsatz von Spezialstahltypen, verbunden mit einer gewissenhaften Projektierung sind Stabilität, Zuverlässigkeit, Langlebigkeit und eine hohe Leistungsfähigkeit gewährleistet. Die Gabeln und die Greiferkörbe können mit hydraulischen Drehmotoren ausgestattet werden.



## HORQUILLAS Y CESTAS

Las horquillas son equipos hidráulicos que sirven para mover ramas, pajas, hierbas, residuos agrícolas e industriales. Se encuentran dos palas juntas accionadas por uno o dos cilindros. Dichas palas están incorporan dientes de gran dureza para garantizar la penetración y recogida de los materiales. Las cestas se usan para la carga de acelgas sobre camiones grúa, excavadoras y cargadores. Están compuestas de una carrocería central con dos valvas insertadas, por su forma y construcción permiten la carga de rocas sin necesidad de recoger arenas o otros tipos de tierra. La serie CSL es una versión diseñada para mover pequeñas cargas de madera usada en plantas de reciclaje y la elaboración de retales de madera. Robustez, confianza, óptimas prestaciones y longevidad están garantizadas gracias a la utilización de aceros especiales y una disposición de los elementos muy cuidadosa. Nuestras horquillas y cestas son aptas para incorporar rotores hidráulicos.

## ВИЛОЧНЫЕ ЗАХВАТЫ И ГРЕЙФЕРЫ ДЛЯ СЕЛЬСКОХОЗЯЙСТВЕННЫХ РАБОТ

Гидравлически управляемые вилочные захваты предназначены для перевалки стружки, сена, соломы, удобрений, травы, отходов садоводства, сельскохозяйственного мусора и промышленных отходов. Грейфер состоит из двух синхронных лепестков, управляемых одним или двумя гидроцилиндрами. Грейферы оборудованы двумя прочными зубьями, изготовленными из износостойкой стали для долговременной службы, заглубления и удержания материала. Сельскохозяйственные грейферы используются на грузовиках, кранах, экскаваторах и погрузчиках. Они состоят из центрального корпуса с двумя челюстями на шарнирах, форма и конструкция позволяет захватывать основной груз, оставляя камни и землю. Серия CSL специально предназначена для перевалки стружки, которая используется при вторичной обработке и переработке лесоматериалов. Надежность, точное исполнение и продолжительный срок службы гарантированы при использовании специальных сталей и мастерского дизайна. Вилочные захваты и грейферы могут быть оборудованы гидравлическим ротатором.

 Esempi di applicazione  
 Examples of application  
 Exemples d'application

 Anwendungsbeispiele  
 Ejemplos de aplicacion  
 Примеры комплектации

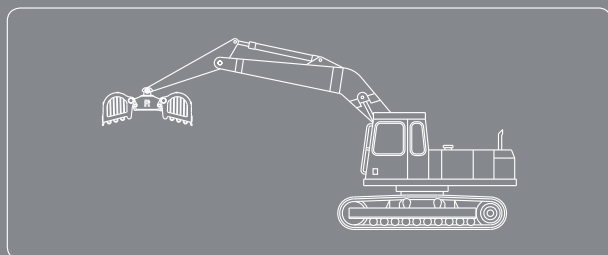
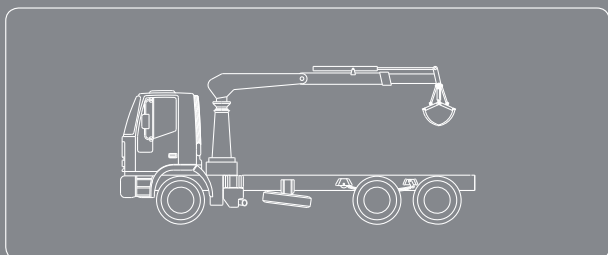

braccio gru  
crane boom

braccio escavatore  
excavator boom

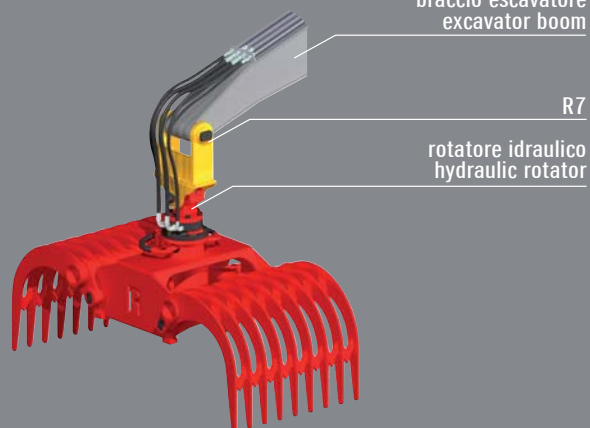
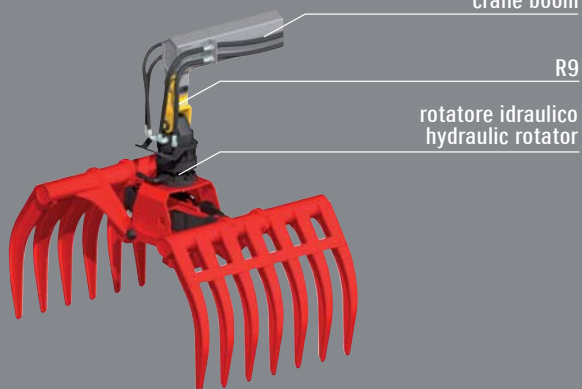

R9

R7

rotatore idraulico  
hydraulic rotator

rotatore idraulico  
hydraulic rotator

braccio gru  
crane boom

braccio escavatore  
excavator boom

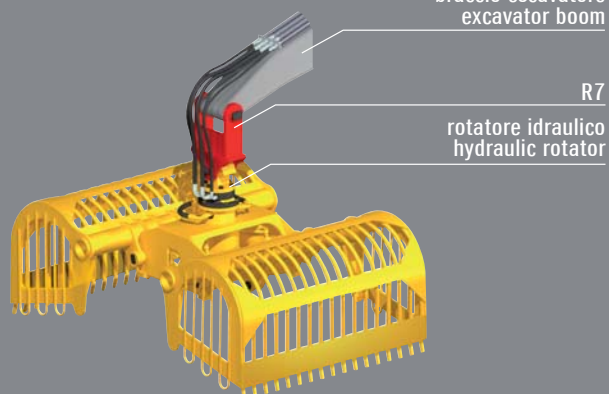
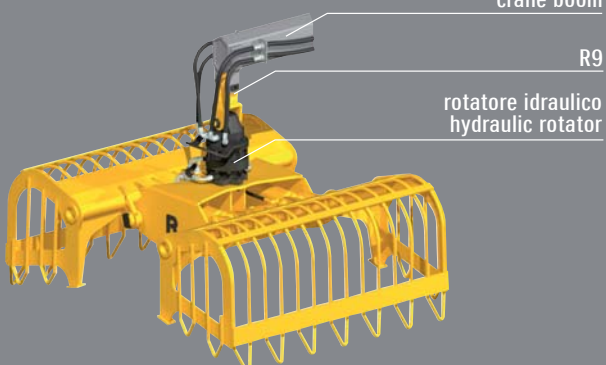







R9

R7

rotatore idraulico  
hydraulic rotator



rotatore idraulico  
hydraulic rotator

 Schemi utilizzo per forche e ceste  
 Scheme of use for forks and grabs  
 Schéma d'emploi pour fourches et bennes

 Anwendungsübersicht für Gabeln und Greiferkörbe  
 Esquema de uso para horquillas y cestas  
 Схема использования вилочных захватов и грейферов

Forche e ceste Forks and grabs	Gancio Hook	Rotatore idraulico Hydraulic rotator	Peso escavatore / caricatore Excavator / loader weight
R69	R9	R102	1.5 - 2.5
R41/145F - 155F	R9	R102 - R103	2 - 3
R70 - R71	R9	R103 - R104	2 - 6
R74FR75 - R74FR100	R9	R104 - R105 - R105H	5 - 10
R175	R7 - R7R	R105H - R3IR - R1G	9 - 16
R176	R7 - R7R	R3IR - R3BIR - R1G - R4G	15 - 25
R10 - 12	R9	R104 - R105	4 - 9
R12,5	R7	R105H - R1G	9 - 15
R13/1500 - 1700 - 2000	R7 - R7R	R3IR - R3BIR - R4G	13 - 20
R13/2250 - 2600 - 3000	R7R	R3BIR - R4G	18 - 25







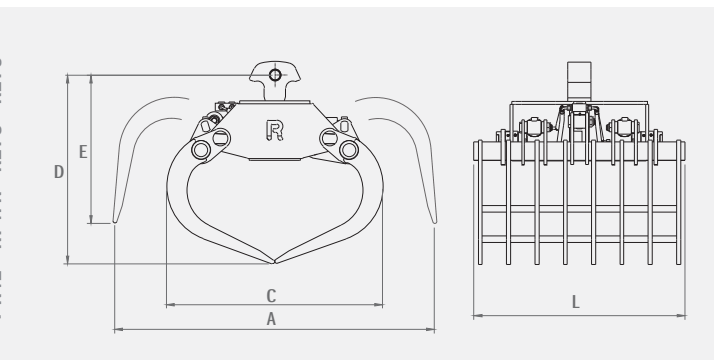
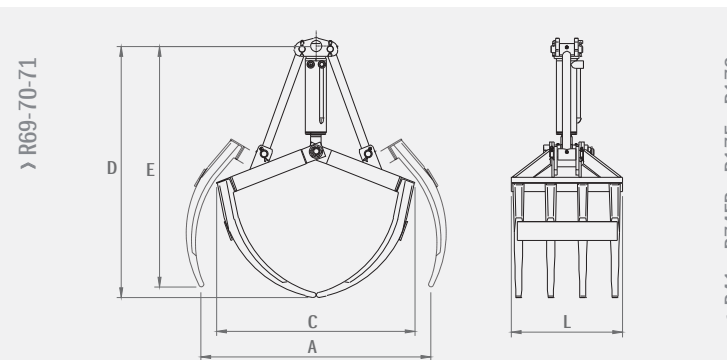
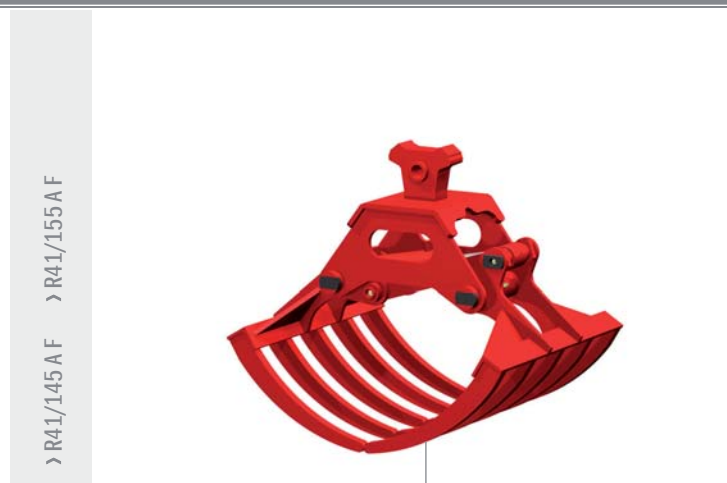

 Forche per la movimentazione letame e materiali diversi  
 Forks for manure's and different materials' handling  
 Fourches pour la manipulation du fumier et de matériaux divers

 Gabeln für Mist - und verschiedenen Materialumschlag  
 Horcas para estiércol y materiales diversos  
 Вилочный грейфер для органических отходов и других материалов



Modello	Peso	Pressione	Portata olio	Numero denti	Dimensioni				
Model	Weight	Pressure	Oil flow	Teeth number	Sizes				
Modèle	Poids	Pression	Débit d'huile	Dents nombre	Dimensions				
Modell	Gewicht	Druck	Ölleistung	Zähne Stück	Abmessungen				
	kg	bar	l/min	N.	A	C	D	E	L
R41/145A F	95	280	20	8	1010	770	630	500	400
R41/155A F	100	280	20	10	1010	770	630	500	600
R69	70	260	30	8	900	790	965	900	450
R70	150	260	60	10	1040	950	1140	1090	600
R71	190	260	60	14	1040	950	1140	1090	930
R74 FR75	300	300	70	9	1470	820	1020	870	720
R74 FR100	350	300	70	13	1470	820	1020	870	1040
R 175	440	280	80	16	1640	1100	960	760	1080
R176	1050	280	90	18	2210	1430	1290	980	1100

 Ceste per movimentazione bietole e materiali diversi  
 Grabs for beets' and different materials' handling  
 Bennes pour la manipulation de betteraves et de matériaux divers

 Greifer für Rüben - und verschiedenen Materialumschlag  
 Cestas para remolacha y materiales diversos  
 Грейфер для погрузки овощей

> R10



> R12.5 > R13



> R12



> R12.5 > R13

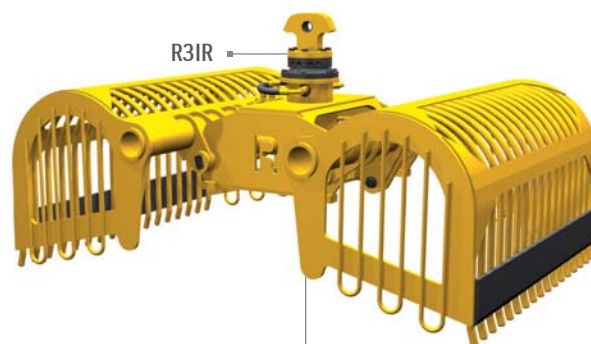

> R10-12

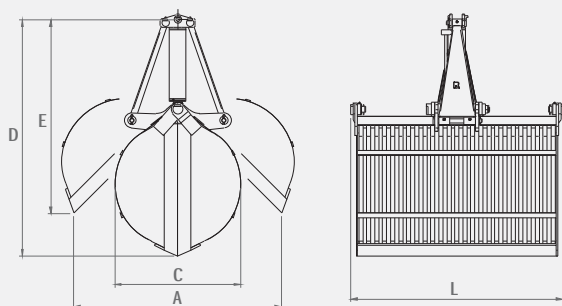

> R12.5-R13

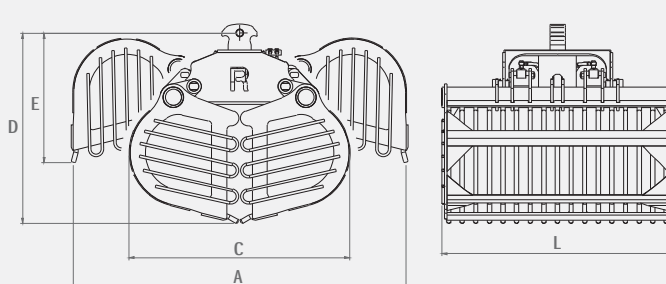

Modello	Peso	Capacità	Pressione	Portata olio	Dimensioni				
Model	Weight	Capacity	Pressure	Oil flow	Sizes				
Modèle	Poids	Capacité	Pression	Débit d'huile	Dimensions				
Modell	Gewicht	Inhalt	Druck	Ölleistung	Abmessungen				
	kg	dm <sup>3</sup>	bar	l/min	A	C	D	E	L
R10	320	500	200	60	1460	760	1430	1330	1250
R12	250	500	200	60	1460	760	1430	1330	1250
R12.5	500	800	250	40	1850	1210	1060	780	1500
R13/1500	930	1200	250	90	2450	1300	1400	1000	1480
R13/1700	960	1350	250	90	2450	1300	1400	1000	1680
R13/2000	1300	2000	250	90	2620	1730	1510	1030	1600
R13/2250	1450	2250	250	90	2620	1730	1510	1030	1820
R13/2600	1600	2600	250	90	2620	1730	1510	1030	2150
R13/3000	1700	3000	250	90	2620	1730	1510	1030	2460





 Trivelle  
 Worm augers  
 Tarières

 Erdbohrer  
 Hoyadoras  
 Шнековые буры специального исполнения

RT130 > R15-A

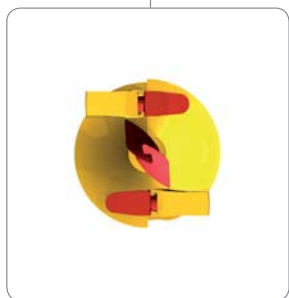
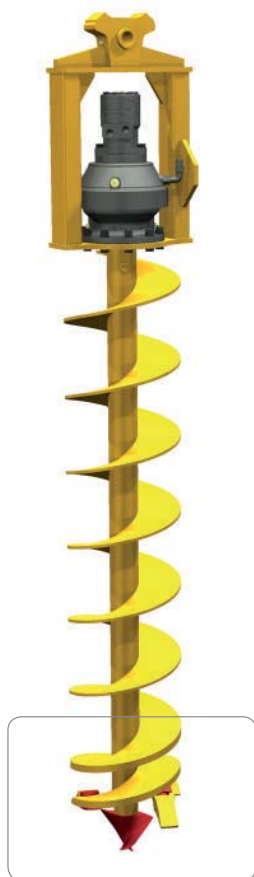

RT170 > R16 > RA

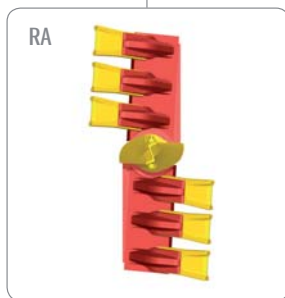

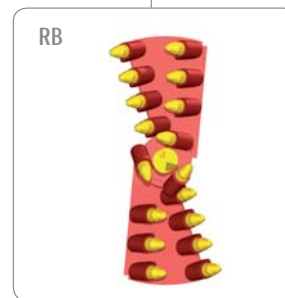

RT750 > R16 > RB



Motoriduttore - Motoreducer - Motorréducteur - Motoruntersetzungsgetriebe

Modello	Peso	Motore	Riduzione	Pressione massima	Coppia	Velocità rotazione	Portata olio massima	Dimensioni	
Model	Weight	Motor	Reduction	Max. pressure	Torque	Rotation speed	Max. oil flow	Sizes	
Modèle	Poids	Moteur	Réduction	Pression maxi	Couple	Vitesse de rotation	Débit d'huile maxi	Dimensions	
Modell	Gewicht	Motor	Reduktion	Max. Druck	Drehmoment	Drehgeschwindigkeit	Max. Ölleistung	Abmessungen	
	kg	cm <sup>3</sup>		bar	daNm	giri/lit	lit/min	C	D
RT130	65	130	1 : 6	200	200	1,3	50	400	600
RT170	120	170	1 : 6	240	330	1	60	460	770
RT750	265	75	1 : 45	350	1885	0,3	160	630	960

 Trivelle  
 Worm augers  
 Tarières

 Erdbohrer  
 Hoyadoras  
 Шнековые буры специального исполнения

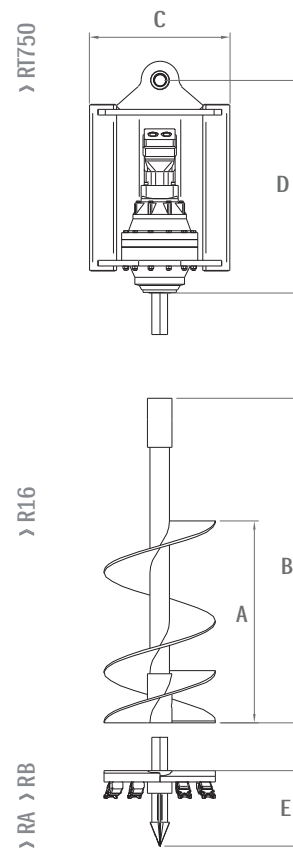
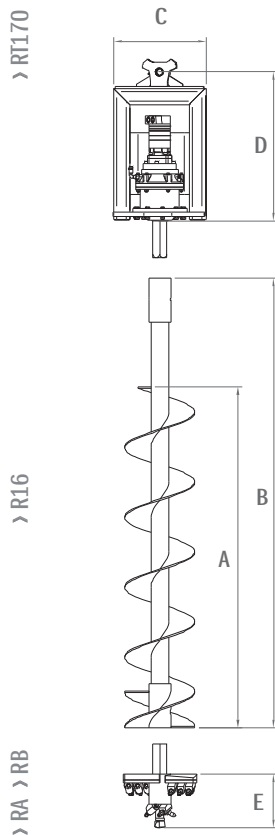
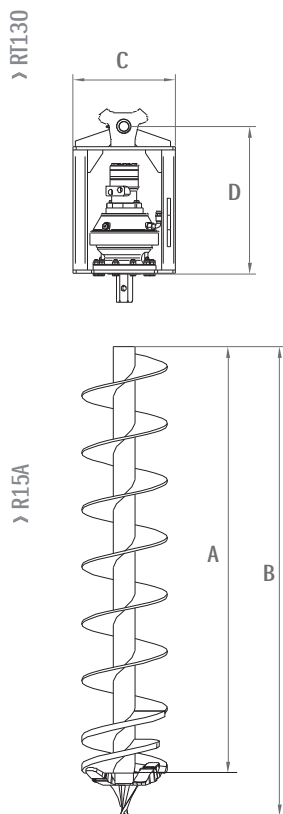

**Coclea - Auger worm - Mèche - Schnecke**

Modello	Diametro	Dimensioni		Peso
Model	Diameter	Sizes		Weight
Modèle	Diamètre	Dimensions		Poids
Modell	Durchmesser	Abmessungen		Gewicht
	mm	A	B	kg
R15A	200	1500	1650	50
	250	1500	1650	60
	300	1500	1650	75
	350	1500	1650	95
	400	1500	1650	105
R16	200	1000	1550	40
		1800	2350	55
	250	1000	1550	45
		1800	2350	60
	300	1000	1550	55
		1800	2350	85
	350	1000	1550	60
		1800	2350	90
	400	1000	1550	70
		1800	2350	110
	500	1000	1550	85
		1800	2350	130
	600	1000	1550	100
		1800	2350	160
750	1000	1550	120	
	1800	2350	195	

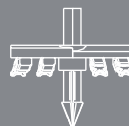



**RA** > punta per terreni normali  
 > auger tip for normal grounds  
 > tête pour terrains normaux  
 > Bohrer für normalen Boden





**RB** > punta per terreni duri  
 > auger tip for hard grounds  
 > tête pour terrains durs  
 > Bohrer für harte Boden

**Punta - Auger tip - Tête - Bohrer**

Modello	Diametro	Dimensioni	Peso
Model	Diameter	Sizes	Weight
Modèle	Diamètre	Dimensions	Poids
Modell	Durchmesser	Abmessungen	Gewicht
	mm	E	kg
RA RB	200	250	23
	250	250	24
	300	250	26
	350	290	33
	400	330	35
	500	330	43
	600	350	47
	750	380	50

 Forca porta pallet  
 Pallet-fork  
 Lève-palette

 Palettengabel  
 Horcas para pallets  
 Вилочный погрузчик поддонов

&gt; R18A



&gt; R21



&gt; R19



&gt; R21

Optional

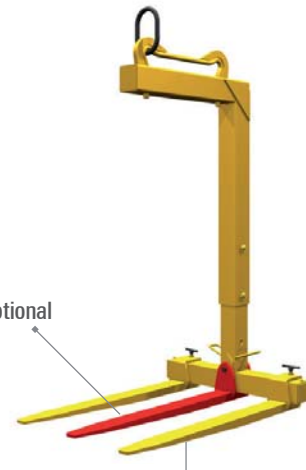

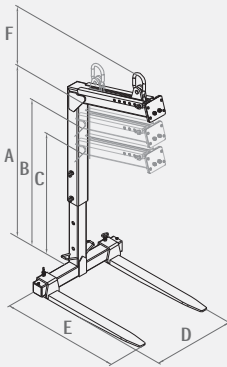

&gt; R18A



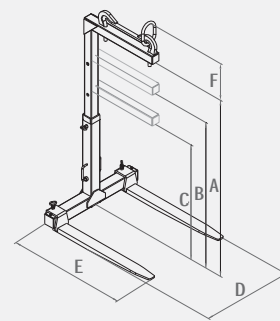

&gt; R19-R21



Modello	Peso	Portata	Dimensioni					
Model	Weight	Lifting capacity	Sizes					
Modèle	Poids	Portée	Dimensions					
Modell	Gewicht	Tragkraft	Abmessungen					
	kg	kg	A	B	C	D	E	F
R18A	180	1800	1740	1500	1240	860	1000	550
R19	120	1000	1700	1410	1100	950	1000	320
R21	165	1800	1800	1550	1300	900	1000	330

 Pinze per la movimentazione di pacchi laterizi e materiali vari  
 Grabs for brick parcels' and different materials' handling  
 Pincés pour la manipulation de bordures et de parpaings et de matériaux divers

 Zangen für Pakete von Ziegeln und verschiedenen Materialumschlag  
 Pinzas para pallets de ladrillos y materiales diversos  
 Грейфер для погрузки брикетов/упаковок

R103F



> R27LE

R104F



> R023

R103F



> R27

R103A



> R29

> R27-R27LE

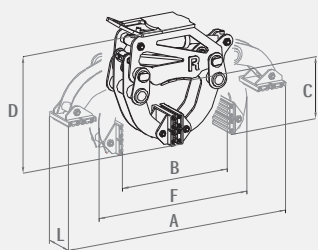

> R023

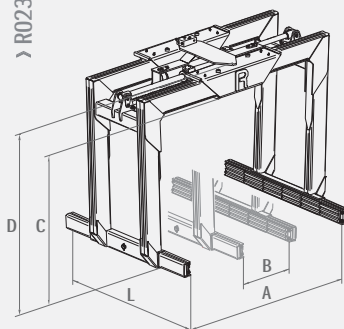

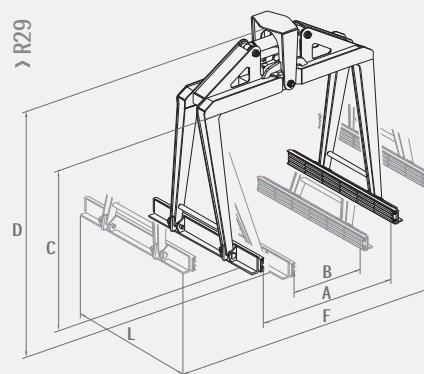

> R29



Modello	Peso	Portata	Pressione	Portata olio	Dimensioni					
Model	Weight	Lifting capacity	Pressure	Oil flow	Sizes					
Modèle	Poids	Portée	Pression	Débit d'huile	Dimensions					
Modell	Gewicht	Tragkraft	Druck	Ölleistung	Abmessungen					
	kg	kg	bar	l/min	A	B	C	D	F	L
R27	225	700	250	50	1640	810	400	830	1140	240
R27LE	135	400	250	30	1460	600	400	770	1010	240
R023	400	1900	250	60	1400	400	1100	1350		1250
R29	270	1800	280	30	1160	600	1100	1720	1610	1200



 Rotatori idraulici  
 Hydraulic rotators  
 Rotators hydrauliques

 Hydraulische Drehmotoren  
 Rotores hidráulicos  
 Гидравлические ротаторы

› R102



› R103A

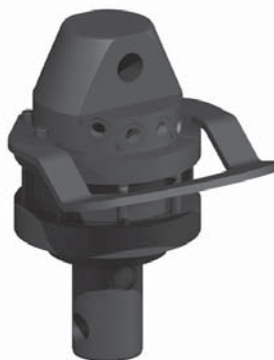

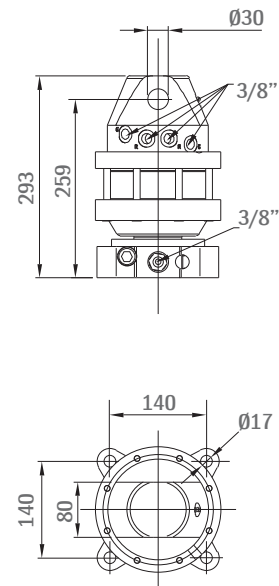
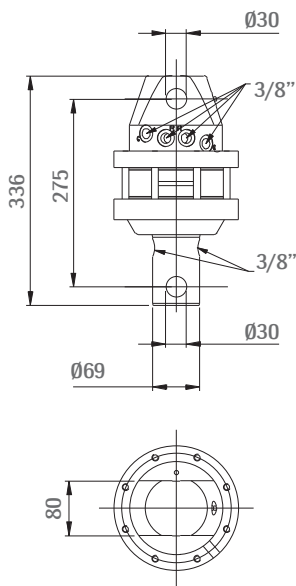
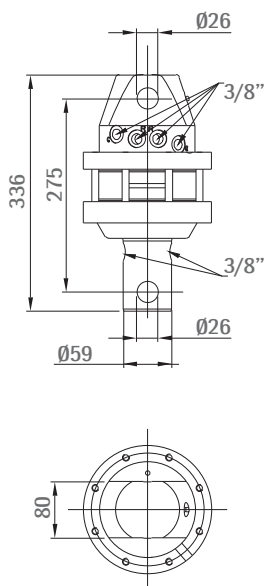
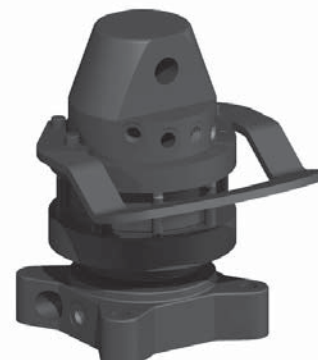

› R103F

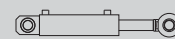
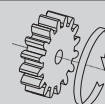
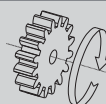

Modello	Portata	Peso	Coppia	Pressione	Portata olio	Pressione
Model	Lifting capacity	Weight	Torque	Pressure	Oil flow	Pressure
Modèle	Portée	Poids	Couple	Pression	Débit d'huile	Pression
Modell	Tragkraft	Gewicht	Drehmoment	Druck	Ölleistung	Druck
	t	kg	kgm	bar	l/min	bar
R102	2	25	100	250	20	300
R103A	2,5	28	110	250	20	300
R103F	2,5	35	110	250	20	300



 Rotatori idraulici  
 Hydraulic rotators  
 Rotators hydrauliques

 Hydraulische Drehmotoren  
 Rotores hidráulicos  
 Гидравлические ротаторы

> R104A

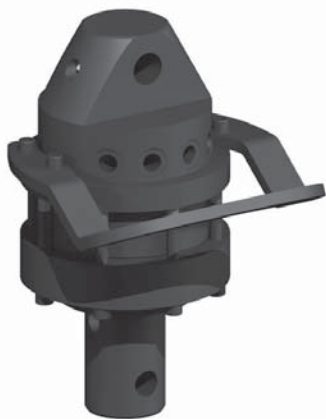

> R104F

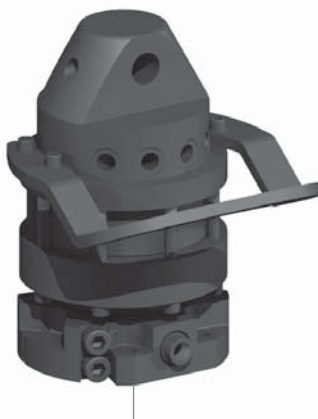

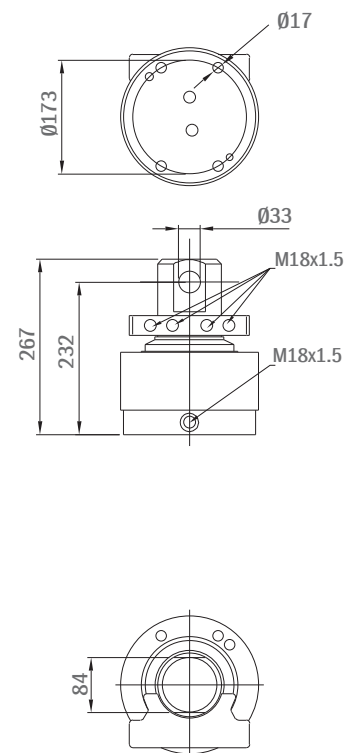
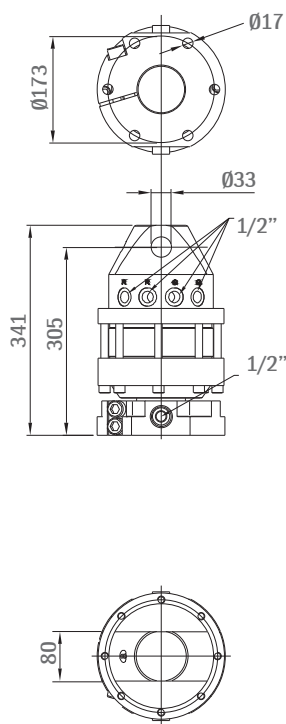
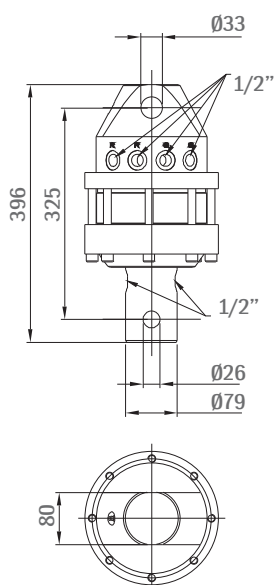

> R05

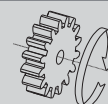
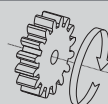

Modello	Portata	Peso	Coppia	Pressione	Portata olio	Pressione
Model	Lifting capacity	Weight	Torque	Pressure	Oil flow	Pressure
Modèle	Portée	Poids	Couple	Pression	Débit d'huile	Pression
Modell	Tragkraft	Gewicht	Drehmoment	Druck	Ölleistung	Druck
	t	kg	kgm	bar	l/min	bar
R104A	3	40	140	250	25	300
R104F	3	46	140	250	25	300
R05	3	31	104	200	20	300



 Rotatori idraulici  
 Hydraulic rotators  
 Rotators hydrauliques

 Hydraulische Drehmotoren  
 Rotores hidráulicos  
 Гидравлические ротаторы

&gt; R105A

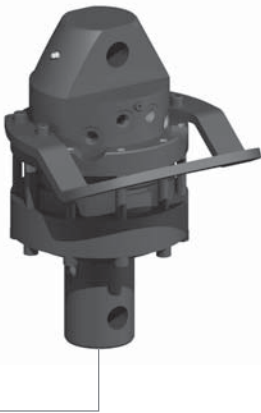

&gt; R105F

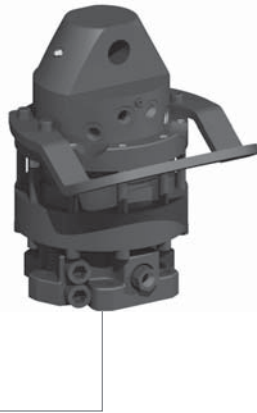

&gt; R105HA



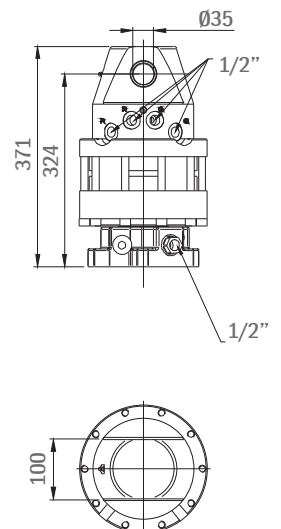
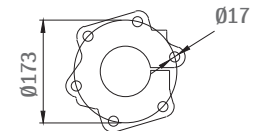
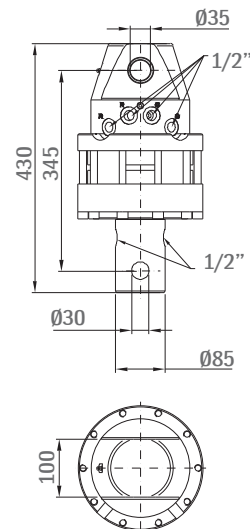
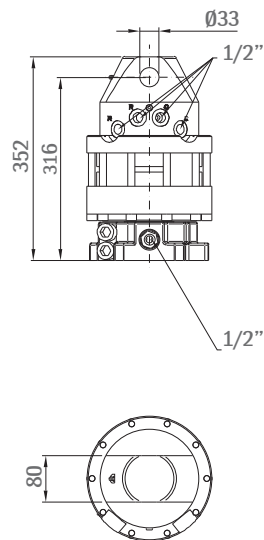
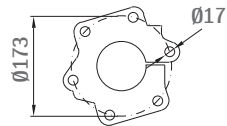
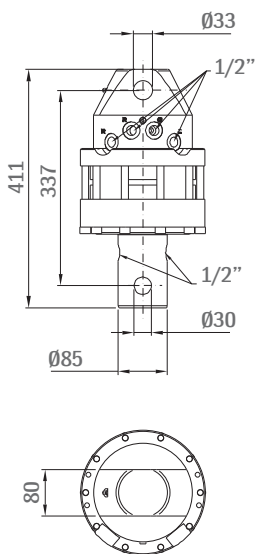

&gt; R105HF

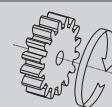
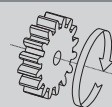

Modello	Portata	Peso	Coppia	Pressione	Portata olio	Pressione
Model	Lifting capacity	Weight	Torque	Pressure	Oil flow	Pressure
Modèle	Portée	Poids	Couple	Pression	Débit d'huile	Pression
Modell	Tragkraft	Gewicht	Drehmoment	Druck	Ölleistung	Druck
	t	kg	kgm	bar	l/min	bar
R105A	4	53	180	250	25	300
R105F	4	60	180	250	25	300
R105HA	4,5	55	180	250	25	300
R105HF	4,5	62	180	250	25	300





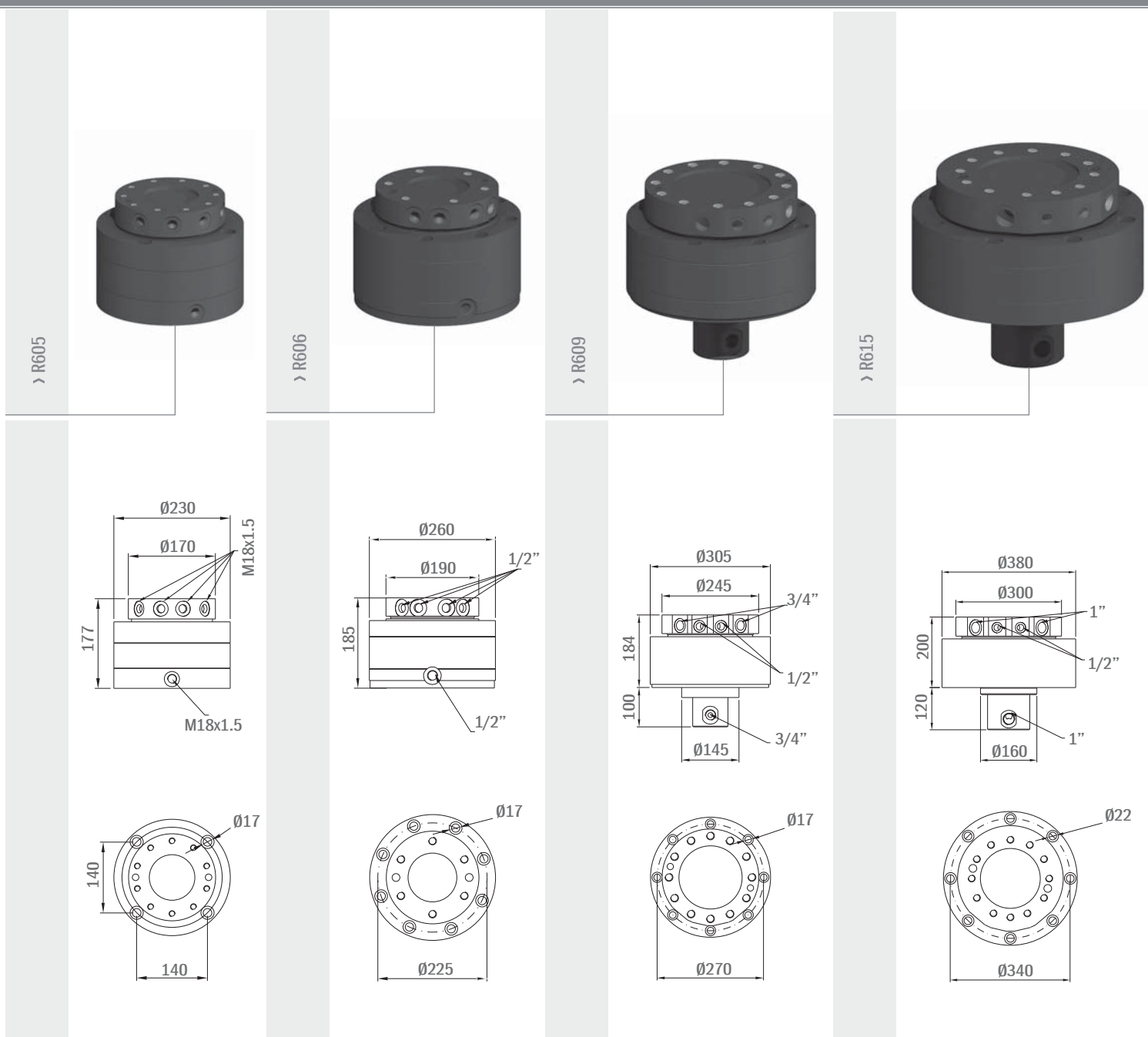

 Rotatori idraulici  
 Hydraulic rotators  
 Rotators hydrauliques

 Hydraulische Drehmotoren  
 Rotores hidráulicos  
 Гидравлические ротаторы

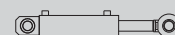
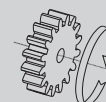

Modello	Portata	Peso	Coppia	Pressione	Portata olio	Pressione
Model	Lifting capacity	Weight	Torque	Pressure	Oil flow	Pressure
Modèle	Portée	Poids	Couple	Pression	Débit d'huile	Pression
Modell	Tragkraft	Gewicht	Drehmoment	Druck	Ölleistung	Druck
	t	kg	kgm	bar	l/min	bar
R605	5	40	125	250	15	350
R606	6	55	165	250	20	350
R609	9	75	300	250	25	350
R615	15	137	550	250	35	350



 Rotatori idraulici  
 Hydraulic rotators  
 Rotators hydrauliques

 Hydraulische Drehmotoren  
 Rotores hidráulicos  
 Гидравлические ротаторы

> R3IR

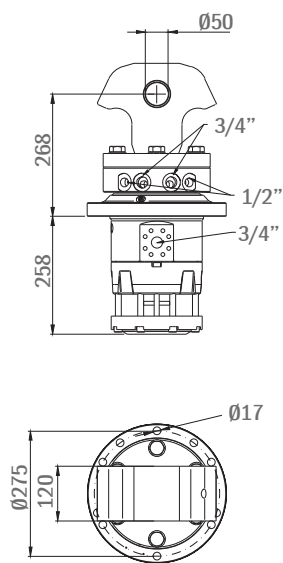

> R3BIR

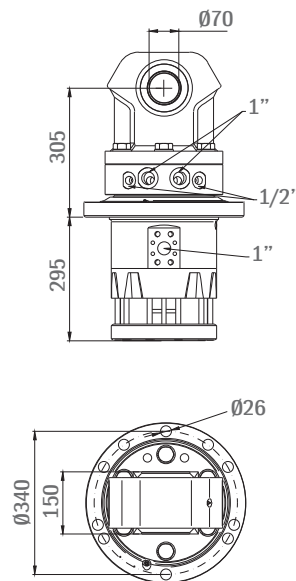

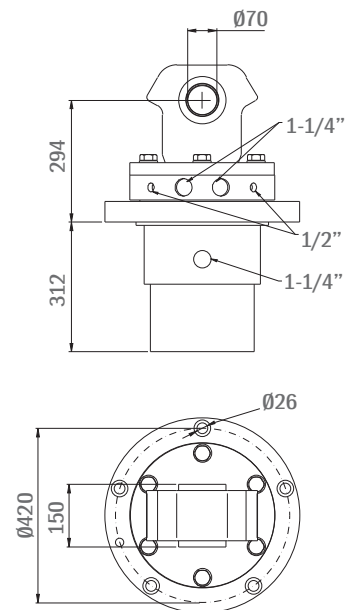

> R3C

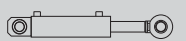
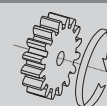
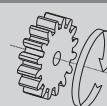

Modello	Portata	Peso	Coppia	Pressione	Portata olio	Pressione
Model	Lifting capacity	Weight	Torque	Pressure	Oil flow	Pressure
Modèle	Portée	Poids	Couple	Pression	Débit d'huile	Pression
Modell	Tragkraft	Gewicht	Drehmoment	Druck	Ölleistung	Druck
	t	kg	kgm	bar	l/min	bar
R3IR	7	125	210	190	25	350
R3BIR	12	205	410	250	35	350
R3C	15	252	240	200	35	300



 Rotatori idraulici  
 Hydraulic rotators  
 Rotators hydrauliques

 Hydraulische Drehmotoren  
 Rotores hidráulicos  
 Гидравлические ротаторы

> R1G

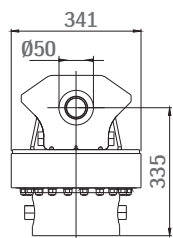
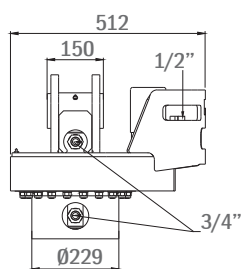

> R4G

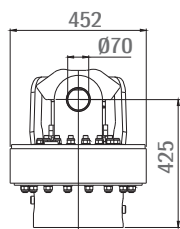
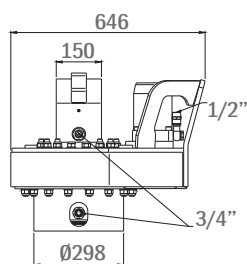

> R640G

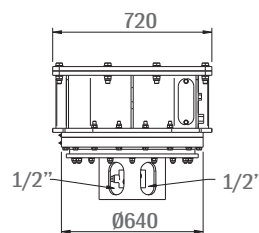
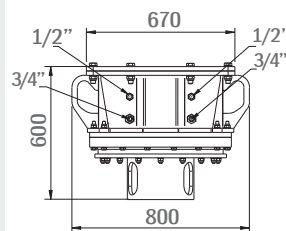
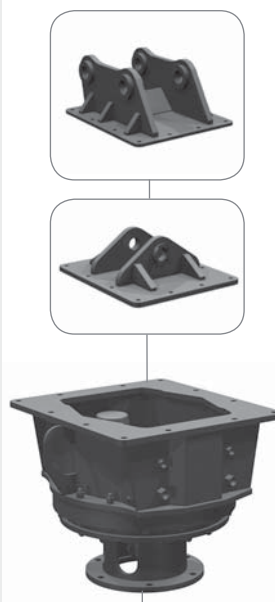

> R5G

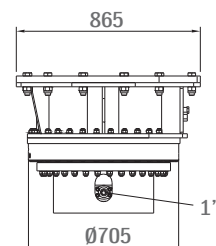
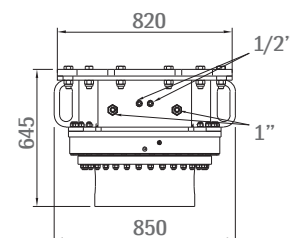
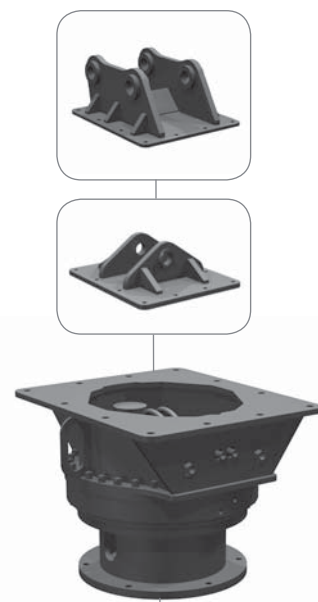

Modello	Portata	Peso	Coppia	Pressione	Portata olio	Pressione
Model	Lifting capacity	Weight	Torque	Pressure	Oil flow	Pressure
Modèle	Portée	Poids	Couple	Pression	Débit d'huile	Pression
Modell	Tragkraft	Gewicht	Drehmoment	Druck	Ölleistung	Druck
	t	kg	kgm	bar	l/min	bar
R1G	5	100	185	110	35	300
R4G	8	220	380	150	40	300
R640G	8	220	290	170	30	300
R5G	18	650	400	200	35	300

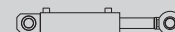
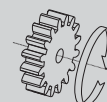
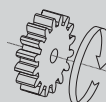



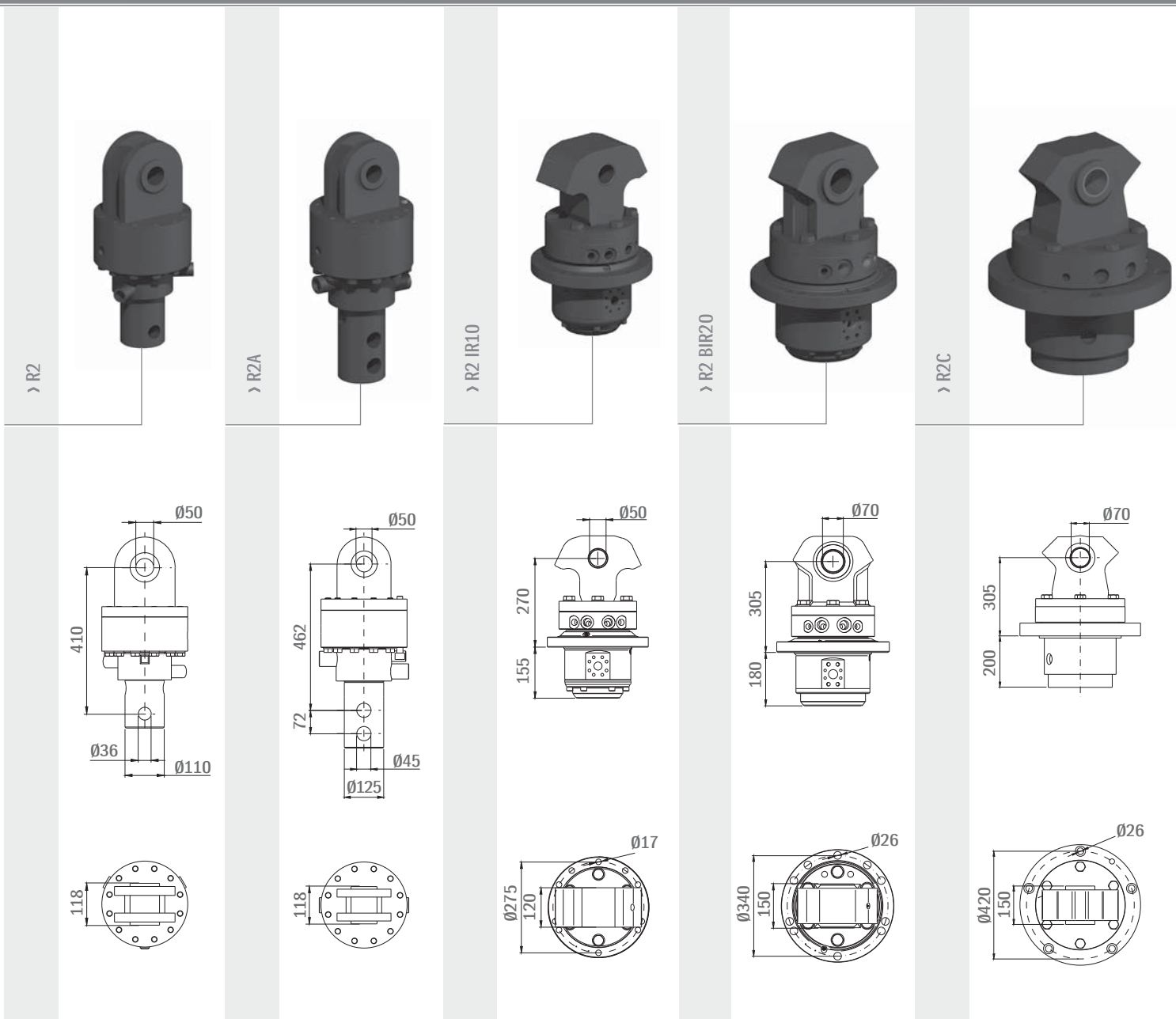

 Giunti idraulici  
 Free rotators  
 Joints tournants hydrauliques

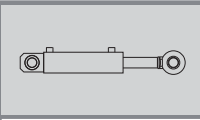

 Hydraulische Drehdurchführungen  
 Juntas hidráulicas  
 Гидравлические ротаторы



Modello	Portata	Peso	Pressione
Model	Lifting capacity	Weight	Pressure
Modèle	Portée	Poids	Pression
Modell	Tragkraft	Gewicht	Druck
	t	kg	bar
R2	6	71	300
R2 IR10	7	130	350
R2A	8	114	300
R2 BIR20	12	175	350
R2C	15	224	300



 Avvolgitubo  
 Hose-reel  
 Enrouleur

 Schlauchwickler  
 Enrollador de tubos  
 Рукавная катушка

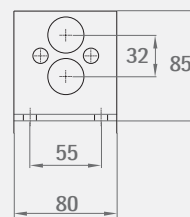
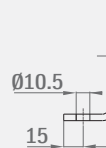
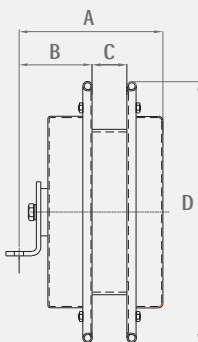
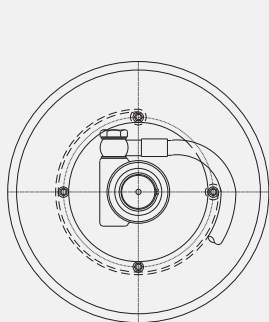

Modello	Corsa	Peso	Pressione	Sezione tubo	Lunghezza tubo	Dimensioni			
Model	Stroke	Weight	Pressure	Hose section	Hose length	Sizes			
Modèle	Course	Poids	Pression	Section du flexible	Longueur du flexible	Dimensions			
Modell	Hub	Gewicht	Druck	Schlauchdurchmesser	Schlauchlänge	Abmessungen			
	m	kg	bar		m	A	B	C	D
<b>RX30</b>	1.9	9	280	3/8"	3	150	70	40	300
<b>RX35</b>	3.9	9.5	280	3/8"	5	150	70	40	350
<b>RX40</b>	6.4	10	280	3/8"	7.5	150	70	40	400
<b>RX45</b>	7.6	29	280	3/8"	9	164	82	40	450
<b>RX52</b>	10.6	31.5	280	3/8"	12	164	82	40	525